

**F3 SERIES  
CASE SIZE 3A  
FILTERED BATTERY CHARGER**

**OPERATION & MAINTENANCE  
MANUAL**

SENS part no.:	101146
Document revision:	F
DCN number	105788
Date	03/19/2010



**1840 Industrial Circle  
Longmont, CO 80501  
Fax: (303) 678-7504  
Tel: (303) 678-7500  
Email: [service@sensusa.com](mailto:service@sensusa.com)  
Web: [www.sens-usa.com](http://www.sens-usa.com)**

**Installation or Service problems? Call SENS at (800) 742-2326 between 8:00 am and 5:00 pm Mountain time Monday through Friday, or visit our website.**

Copyright © Stored Energy Systems LLC 2006

**IMPORTANT SAFETY INSTRUCTIONS**

## SAVE THESE INSTRUCTIONS

This manual contains important safety and operating instructions for Stored Energy Systems (SENS) model F3.

Before using the battery charger, read all instructions and cautionary markings on the battery charger, battery and equipment connected to the battery system.

**WARNING:**  
Please read these safety warnings and heed them. Failure to do so could result in either severe personal injury or equipment damage.

This equipment uses and generates potentially lethal voltages. The equipment should only be installed and maintained by trained persons. Do not attempt to install or operate this equipment unless you are certain you are adequately trained.

To reduce the risk of injury, charge only properly sized lead-acid or nickel cadmium batteries. Other types of batteries or under-sized batteries may burst causing personal injury and damage.

- Do not install or operate charger if it has been dropped or otherwise damaged. Return it to the factory for repair.
- Install the charger in accordance with all local codes.
- Do not expose charger to rain or snow.
- Do not disassemble charger; return to factory when service or repair is required. Incorrect assembly may result in a risk of electric shock or fire.
- To reduce risk of electric shock, de-energize and disconnect the AC input and the battery from the charger before attempting maintenance or cleaning.
- Use of an accessory not recommended or sold by SENS may result in a risk of fire, electric shock or personal injury.
- During normal operation, batteries may produce explosive hydrogen gas. *Never smoke, use an open flame, or create sparks near the battery or charger.*
- Remove jewelry, watches, rings, etc. before installing battery or charger.

### Maintenance Instructions

User maintenance is limited to charger adjustment. All on-site servicing should be performed by qualified service personnel. If qualified personnel are not available, return the charger to the factory for repair, or contact the factory to arrange for field service.

When returning a unit to the factory for repair, ship it in the original factory packaging if possible. If the original carton is not available, pack in a carton with at least 2 inches of approved packaging material on all sides of the charger to help prevent shipping damage.

# 1 Overview

This manual covers installation, operation and troubleshooting of SENS model F3 filtered battery charger.

## 1.1 READ THIS FIRST

Please follow the installation and use instructions. They are vital to the satisfactory operation of the charger. If you have any doubts about adjusting, maintaining or servicing the equipment, contact SENS service department.

Changing factory-set potentiometers *voids the warranty*. Contact the factory if you believe that the settings on your charger are incorrect. Before determining that the charger is not working correctly, check the following:

1. Are three phases of AC power available to the charger?
2. Are any circuit breakers tripped or fuses blown?
3. Is the charger connected to a battery of the correct voltage?
4. Was the charger damaged in transit or installation?
5. The charger may have shut down to excessive output voltage. To ensure that the high volt shutdown has been reset, turn off both the AC input breaker and DC output breaker for five minutes. This is more than sufficient time for the DC voltage to decay and reset the shutdown.
6. If the battery is being over- or undercharged, check whether the output voltage settings have been tampered with. The pots should be covered with either white adhesive paper dots or a hard colored varnish. *Under no circumstances change the adjustment of control board pots other than R33 and R34.*

## 1.1 Description and Application

The F3 is a fully automatic battery charger and DC current source offering the following features:

- Constant voltage output
- Electronic current limiting
- Filtered output (on battery rated in AH four times amp rating of charger): 12, 24, 48V: 30 mV rms; 110, 120V: 150 mV rms; 144, 240V: 300 mV rms
- Filtered output without battery: 12, 24, 48V: 100 mV rms
- With optional filter for 110 & 120V models: 30mV rms on battery, 300mV without battery
- Temperature compensation to maximize battery performance and life
- Circuit breakers for AC input and DC output

The chargers are designed to supply equipment requiring a low ripple DC source and to automatically recharge and maintain a parallel connected lead-acid or nickel-cadmium battery.

## 1.2 Upon Delivery

Inspect the charger for damage caused during transit, and report damage to the carrier immediately. Then contact SENS to determine how best to repair/replace the damaged unit.

# 2 Installation

## 2.1 Mechanical Installation

**Caution:** Heed the following warning to prevent damaging the lower cover of the charger!

**FIGURE 2.1**  
**Lifting Instructions**

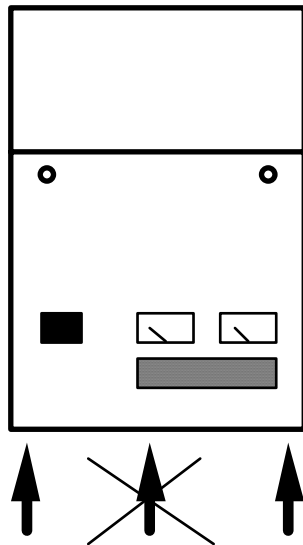

**WHEN INSTALLING  
DO NOT LIFT UNIT  
FROM MIDDLE OF  
LOWER COVER - THE  
COVER WILL BEND.**

**USE A SPREADER  
PLATE EQUIVALENT TO  
1" THICK PLYWOOD  
ACROSS THE BOTTOM  
OF THE UNIT WHEN  
LIFTING**

The charger can be mounted either on a wall or in a standard 23" relay rack. Locate the charger in a dry place as close to the battery and load as possible to minimize voltage drop.

---

**WARNING:** These chargers are *not* approved for operation in mines or other places with explosive atmospheres

---

#### Wall Mounting

Mount the system to a robust wall using 1/4" bolts with flat washers behind the mounting holes if necessary to level the charger on an uneven wall. The charger should be located as close to the battery and load as possible to reduce voltage drop in the charging leads. Refer to the mechanical drawings at the end of this document for case dimensions and mounting dimensions.

#### Relay Rack Mounting

The charger is shipped on its back with the mounting flanges in the wall-mount position. Place the charger in a vertical position, then unbolt and reverse the mounting flanges. **CAUTION:** *When changing the angles from wall mount (the standard shipping configuration) to rack mount, you MUST either stand the charger up vertically, or otherwise remove the charger's weight from the rack angles when removing the rack angle bolts. If you do not, the bolts in heavy chargers may strip on their way out.*

Protect the charger from construction grit, metal chips, paint or other debris. Clean away debris after installation and before turning on the charger.

#### Ventilation

The charger is designed to be convection cooled. Required clearances around the unit for proper cooling are 6 inches on the top and 4 inches on the bottom.

## **2.2 Electrical - Power Wiring**

---

**WARNING:** Heat sinks and many other metallic components inside the charger are LIVE with either line or output voltage. These voltages can be lethal. Do not touch any exposed metal surfaces inside the enclosure while the charger is operating.

---

Remove the two 1/4-turn fasteners securing the charger's top front panel and open the front panel. Make AC and DC connections direct to the AC and DC circuit breakers in accordance with diagram 2.2 below.

**Caution:** Small sense leads are connected to the output side of the DC breaker. These must remain

connected to the output side of the breaker after installation of the DC cabling, or the charger will not function properly.

**FIGURE 2.2  
Power Connections**

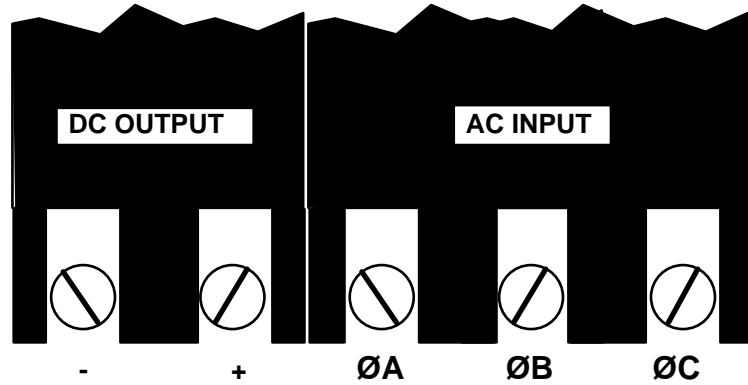

Connection should be made by a qualified installer in accordance with national and local electrical codes. The installer should determine the gauge of wire to be used based on the length of cable run and the ampere requirements of the charger. Size the DC cabling to keep voltage drop in the charging leads as low as possible.

Refer to TABLE 2.2 for the charger’s AC requirement of your charger. The input voltage and frequency are marked on the charger’s front panel. Maximum current consumption will be approximately 75% to 80% of the breaker’s rating. Typical efficiency is 85% for 24 volt units, 88% for 48 volt units and 91%+ for 120 and 240 volt units. Power factor is approximately 0.8 at rated input voltage.

**WARNING:** The battery charger must be connected to a grounded permanent wiring system. A ground stud or terminal is provided for this purpose

**TABLE 2.2  
AC Input Circuit Breaker Ratings**

Charger output				Rated Charger AC Circuit Breaker (/Phase)					
				208V	240V	380V	400V	415V	480V
V	A	V	A	amps	amps	amps	amps	amps	amps
24	100	48	50	15	15	15	15	15	15
24	150	48	75	20	20	15	15	15	15
24	200	48	100	30	25	15	15	15	15
		48	150	40	35	25	25	20	20
		48	200	60	50	30	30	30	25
			120	25	20	15	15	15	15
			120	35	25	25	15	15	15
			120	50	35	35	20	20	15
			120	75	50	50	30	30	25
			120	100	70	70	40	35	30
			168	30					15
			96	50					20
			110	100			40		

		144	30					15
--	--	-----	----	--	--	--	--	----

**Caution:** Do NOT connect the battery backwards; charger damage may result

The voltmeter will show battery voltage as soon as the DC connection is completed. Check the voltmeter as soon as the DC connection has been made. If the meter reads zero or is deflecting below zero, reverse the polarity of the battery connections.

**2.3 Alarm Connections**

F3 chargers are supplied with one of three following alarms configurations:

**TABLE 2.3  
Charger Part Number Suffix and Alarms Configuration**

Second digit of part number suffix (e.g. "F5E2")

Alarms "0"	Alarms "5"	Alarms "6"	< Alarm system code Indications
none	Float or boost mode	Float or boost mode	LED
none	AC fail	AC fail	LED & Form C contact
none	Charger fail	Charger fail	LED & Form C contact
none	Low battery voltage	Low battery voltage	LED & Form C contact
none	High battery voltage	High battery voltage	LED & Form C contact
none	none	Ground fault	LED
none	none	Ground fault -	LED
none	none	Ground fault + or -	Form C contact
none	Summary of above	Summary of above	Form C contact

Connect to the charger's Form C contacts according to Figure 2.3

1. Make connections to the system's Form C alarm contacts as shown.
2. Run alarm wiring out of the charger separately from the AC supply wiring
3. Use 16 to 22-gauge wire.
4. NOTE: Do not exceed the relay maximum current rating of 0.5A @ 117 VAC or 1A @ 24 VDC.

The remote alarm connection board is located on the circuit breaker pan, adjacent to the control board. See Figure 2.3 on next page.

**FIGURE 2.3  
Remote Contact Terminal Block**

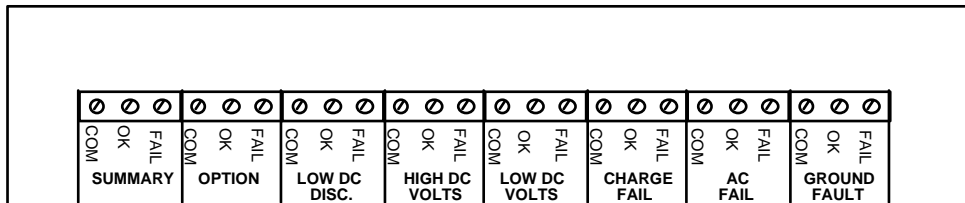

**2.4 Temperature Compensation**

F3 chargers include battery temperature compensation (TC). TC is required by all batteries for maximum

performance and life. The TC feature automatically reduces the charger's output voltage at high temperatures and vice-versa.

The F3 has provision for either local or remote sensing of temperature. Local sensing is done by components located on the charger's control board, which is exposed to the ambient air. At installations where the battery is located in a different room, or is otherwise subject to ambient temperatures different from the charger it is necessary to sense temperature at the battery. The SENS remote sensor is optional. The control board automatically selects the remote sensor over the local sensor. If the remote sensor is damaged or disconnected temperature sensing automatically reverts to local.

The two leads of the RTS are connected to a port on the control board as follows: Connect the yellow lead of the sensor to J6 "K" and the violet lead to J6 "A". If the sensor is connected properly D12 will not illuminate when the charger is in operation. If D12 stays lit, check that RTS leads are not reversed, and check that the RTS is not damaged. Any excess length of the RTS leads should be cut off rather than coiled, to ensure the shortest possible length. The RTS leads should be routed separately and away from all other AC power, DC power, and alarm wires and cables to prevent noise coupling that may cause abnormal operation of the charger.

---

**NOTE:** D12 on the control board will remain lit whenever the remote temperature sensor is either not used, or if the remote sensor is disabled. This is normal when RTS is not used.

---

## 3 Operation

### 3.1 Start-up

Start with both input and output breakers OFF.

First, check that the connected battery voltage is correct (e.g. 120 volts for a 120 volt charger). It is OK if the battery voltage is different from the nominal value by a few percent. If the battery voltage is more than 10% different from the rated voltage of the charger, recheck your connections **BEFORE** turning on either breaker.

First close the AC input breaker. Check that the charger voltage comes up to approximately 15% above nominal. (Some voltage overshoot on initial startup is normal).

Next close the DC output breaker. The charger will immediately begin to supply current if required by the battery or load.

In chargers with alarms code "5" or "6", the front panel AC FAIL and CHARGE FAIL lights will extinguish, and should be replaced by the green AC ON light.

The charger will automatically supply power to the load and maintain the battery without further attention. If the charger does not start as described, or appears to have failed, check the following:

- Verify that AC mains power is available
- Verify that no external circuit breakers are tripped
- Verify that contractor-installed AC, DC and alarm connections are correct
- **Disconnect AC and DC power sources.** Open the charger. Verify that no components (e.g. main DC output fuse, if fitted) or harness connections are blown, loose or damaged

If all of the above appear to be in order, contact SENS at the toll-free service number on the front of this document for assistance in troubleshooting.

### 3.2 FLOAT/BOOST MODES

Two modes of voltage control are provided in all F3 chargers as follows:

#### FLOAT

The float mode is the battery "maintenance" voltage. It is the normally fully charged voltage of the battery. This is the normal charging position for all batteries, and the recommended charging position at

all times for Valve Regulated Lead Acid (VRLA) batteries.

### BOOST

This voltage is slightly higher than the float setting. Boost slightly overcharges the battery in order to ensure that all the cells of a battery are fully charged to the same voltage. Continued operation in boost is *not* recommended because the high charging voltage will cause battery electrolyte to boil away quickly. This is a particular problem with VRLA batteries where there is no way to replenish lost electrolyte.

### **3.3 FLOAT/BOOST CONTROL**

F3 chargers are equipped with one of the four following float/boost voltage control systems depending on the configuration ordered:

#### FLOAT/BOOST front panel rotary switch

The charger will operate indefinitely in the mode that is selected. The AUTO position may be shown on the front panel. If the AUTO position is locked out, the AUTOBOOST feature is not supplied.

#### AUTO/FLOAT/BOOST front panel rotary switch

When the selector switch is in the FLOAT or BOOST mode the charger will operate indefinitely in the mode that is selected.

The AUTO mode selects automatic equalization of the battery. The charger determines when the battery is in need of fast charging, and operates in the fast charge boost mode only until the battery is fully charged. The charger determines state of charge by the measuring the amount of current drawn from the output terminals. When the selector switch is in the AUTO position the charger will start in the boost mode and stay there until current demanded drops below about 50% of the charger's rated current. When current demand increases to about 70% of the charger's rated output the charger will resume operation in the boost mode.

Please see the Appendix for a diagram of how the Autoboot system works. The AUTO setting eliminates the need to periodically equalize the cells of a battery as the charger does this automatically. *The AUTO position should not be selected when the continuous load on the charger is greater than about 50% of the charger's maximum rated current.*

#### Manually initiated boost timer (either 0-24 hours or 0-72 hours)

When the timer is turned clockwise the charger will be in boost mode, where it will remain until the timer returns to 0 hours. At the end of the selected time the charger will return to float mode.

#### Manually initiated boost timer plus AUTO/FLOAT/BOOST rotary switch

Selection of the AUTO position allows the charger to operate in the AUTOBOOST mode (described above)

Selection of the FLOAT mode forces the charger to remain in the float mode *unless* the boost timer is activated by turning past zero. If the boost timer is activated, the charger will revert to float mode after the time selected on the timer expires.

Selection of the BOOST mode forces the charger into boost charge, where it will remain until BOOST is deselected manually.

### **3.4 Alarm Indications**

**NOTE:** Chargers are equipped with a "dead-front" panel. Alarm LEDs are behind the dead front panel and will be visible when they illuminate due to an alarm condition, or when the TEST button is pressed. See Figure 3.5 for the location of LED indicators. Chargers with no alarms (alarms code "0") have no LEDs or test button.

**FIGURE 3.4**  
**LED Indicators on Charger Front Panel**

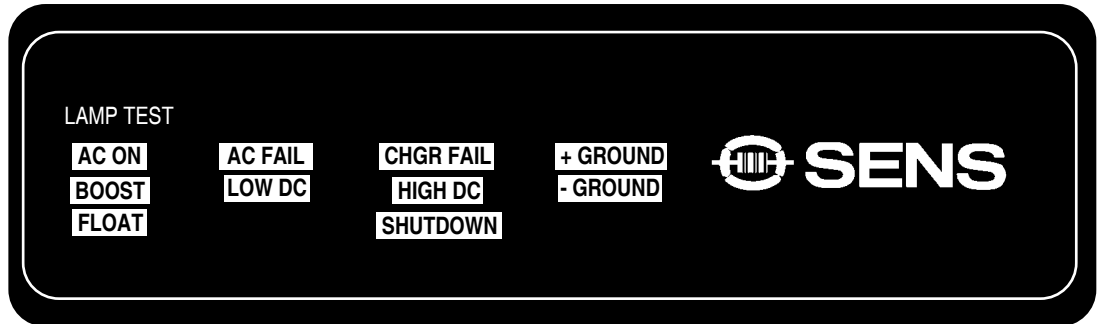

AC ON

Indicates that AC power is being supplied to the charger.

BOOST

The charger is operating in the BOOST mode.

FLOAT

The charger is operating in the FLOAT mode.

AC FAIL

Indicates that AC power is not available to the charger. Input AC is failed, or AC breaker is tripped.

CHGR FAIL

Indicates that the charger is failing to produce the output current required by the battery and load. When the battery and load demand no current the failure alarm will not activate.

In the event that the CHARGE FAIL and AC ON lights are illuminated simultaneously, then the charger has failed. The probable causes of an alarm, in descending order of likelihood are:

- a) A failure of AC power
- b) A tripped AC breaker
- c) The charger has malfunctioned

LOW DC

Indicates that DC voltage has dropped to approximately 8.5% below nominal battery voltage (e.g. 22 volts for a 24 volt system). Probable causes:

- a) The AC power has failed, and the battery has become discharged
- b) The charger has malfunctioned and the battery has become discharged
- c) The battery is defective

There is a time delay in the low voltage alarm which prevents the alarm from activating until approximately 30 seconds after the low voltage condition starts.

HIGH DC

Indicates that the charger's output has exceeded a pre-set threshold level (approximately 20% above nominal battery voltage - e.g. 29 volts for a 24 volt system). If this alarm stays activated for any period of time, the charger should be shut down and serviced. The charger may have malfunctioned, or the alarm card may be misadjusted. The alarm activates immediately upon high voltage condition, but stays activated

for approximately 30 seconds after the condition disappears.

### HIGH DC SHTDN

Indicates that the charger has been shut down by the high output voltage shutdown circuit. Probable causes of a high DC shutdown are as follows:

- a) The float or boost voltages have been increased above the pre-set shutdown voltage
- b) The high voltage shutdown set point has been changed from the factory setting.
- c) The charger has malfunctioned, and is not regulating properly.

There is a delay of approximately 5 seconds after the onset of the high voltage condition until the unit shuts down. When a high volt shutdown occurs, the red HVS LED on the control board will illuminate, along with the SHUTDOWN LED on the front panel.

If the high DC shutdown activates the charger will stay off until the battery voltage drops to approximately nominal, at which point the circuit will reset and the charger will start. Manual reset of the shutdown is accomplished as follows:

- 1) Turn off the AC input breaker. (Note that while the SHUTDOWN LED will extinguish, the charger is still locked out. This is because the shutdown LED is driven by the control board's power supply, which is derived from the AC supply, rather than from battery).
- 2) Turn off the DC output breaker.
- 3) Wait for about one minute for capacitor voltage to decay through the capacitor bleeder resistor
- 4) Turn on the DC output breaker
- 5) Turn on the AC input breaker. If the charger is still in high DC shutdown, repeat steps 1 through 3, waiting longer before turning DC and AC breakers back on.

The control board includes two sets of Form C contacts for high volt shutdown indication. Either one of these can be used for remote indication of high voltage shutdown.

### GROUND (optional)

This is a ground fault alarm. If either the charger's positive or negative is connected to ground, even through a high resistance path, this alarm will activate. LEDs indicate either positive or negative grounding. The Form C contact only indicates that a fault has occurred.

Some applications require that ground be referenced to either the positive or negative output. In this case, the activated ground fault alarm will be a nuisance. The alarm can be safely disabled by placing the ground fault jumper located on the alarm board (mounted on the charger's front door) in the "disabled" position. When pins 1 and 2 of J5 are connected together the ground fault alarm is disabled. When pins 2 and 3 are connected the ground fault alarm is enabled.

## 4 Adjustments

### 4.1 Output Voltage Adjustment

---

**WARNING:** Working inside the charger exposes you to dangerous AC and DC voltages. Do not touch circuit breakers, filter capacitors, heat sinks or any other exposed metal surfaces

---

**NOTE:** Do not tamper with factory adjustments unless sure adjustment is necessary. Temperature-compensated control circuitry automatically adjusts the output voltage depending on temperature. Adjust the output only under these circumstances:

- a) To correct a previous unauthorized adjustment
- b) To adjust the charger for a different type of battery (e.g. from lead-acid to nickel-cadmium)
- c) If your battery is consistently being over-charged or under-charged

**NOTE:** Unless authorized by SENS, any charger adjustment, including output voltage adjustment, voids the warranty.

#### Procedure

1. Use a precision external voltmeter connected directly to the charger output terminals.
2. Set the charger’s front panel FLOAT/BOOST control to FLOAT.
3. Open the charger’s front panel and locate the control card. It contains two potentiometers labeled “FLOAT” (R34) and “BOOST” (R33), both located next to one of the control transformers.
4. Adjust the FLOAT pot until the desired voltage is achieved.

Adjustment of the BOOST voltage is similar to adjustment of FLOAT, except that you adjust the BOOST pot instead of the FLOAT pot. Be sure that the charger front panel mode switch is in BOOST when you make adjustments.

Please note that the BOOST adjustment controls the level above FLOAT voltage, not the absolute voltage. Therefore, whenever the FLOAT the voltage is changed, the BOOST voltage also changes.

**4.2 Factory-Set Output and Alarm Voltages**

**NOTE:** Output voltages are temperature compensated (vary with temperature). The factory settings below are at 20 degrees C. The compensation is -0.18% per degree C. The alarm voltage settings are NOT temperature compensated.

*Chargers set for sealed maintenance-free lead-acid battery*

	12 volt	24 volt	32 volt	48 volt	120 volt	168 volts	240 volt
Float voltage	13.62	27.24	36.32	54.48	136.20	190.68	272.40
Boost voltage	13.80	27.60	36.80	55.20	138.00	193.20	276.00
Low DC alarm	11.00	22.00	29.33	44.00	110.00	154.00	220.00
High DC alarm	14.61	29.22	38.96	58.44	146.10	204.54	292.21
High DC shutdown	15.19	30.39	40.52	60.78	151.95	212.73	303.89

*Chargers set for flooded lead-acid battery*

	12 volt	24 volt	32 volt	48 volt	120 volt	168 volts	240 volt
Float voltage	13.32	26.64	35.52	53.28	133.20	186.48	266.40
Boost voltage	14.00	28.00	37.28	55.92	139.80	196.00	279.60
Low DC alarm	11.00	22.00	29.33	44.00	110.00	154.00	220.00
High DC alarm	14.82	29.64	39.47	59.20	148.01	207.48	296.02
High DC shutdown	15.41	30.83	41.05	61.57	153.93	215.50	307.86

*Chargers set for nickel cadmium battery Multiply volts per cell times # of cells for actual voltage*

	Per Cell
Float voltage	1.43
Boost voltage	1.52
Low DC alarm	1.19
High DC alarm	1.61
High DC shutdown	1.67

Chart 4.2 shows relationships between charger output voltage, alarms and high volt shutdown. Output voltage is temperature compensated down to ten degrees C; compensation then ends.

To determine the charger’s voltage at temperatures other than 20 deg. C., multiply number of degrees C difference between ambient and twenty C times .0018. Multiply that product times the factory voltage setting (e.g. 27.24) and add it to the factory setting. Examples:

**Example 1:** Float voltage at 10 degrees C of a 24 volt charger set for 27.24 volts at 20 degrees C:  
 $20-10 (.0018) (27.24) + 27.24 = \mathbf{27.73}$  volts

**Example 2:** Float voltage at 50 degrees C of a 24 volt charger set for 27.24 volts at 20 degrees C:  
 $20-50 (.0018) (27.24) + 27.24 = \mathbf{25.77}$  volts

**CHART 4.2**  
**Graph of Factory-Set Output, Alarm and Shutdown Voltages**

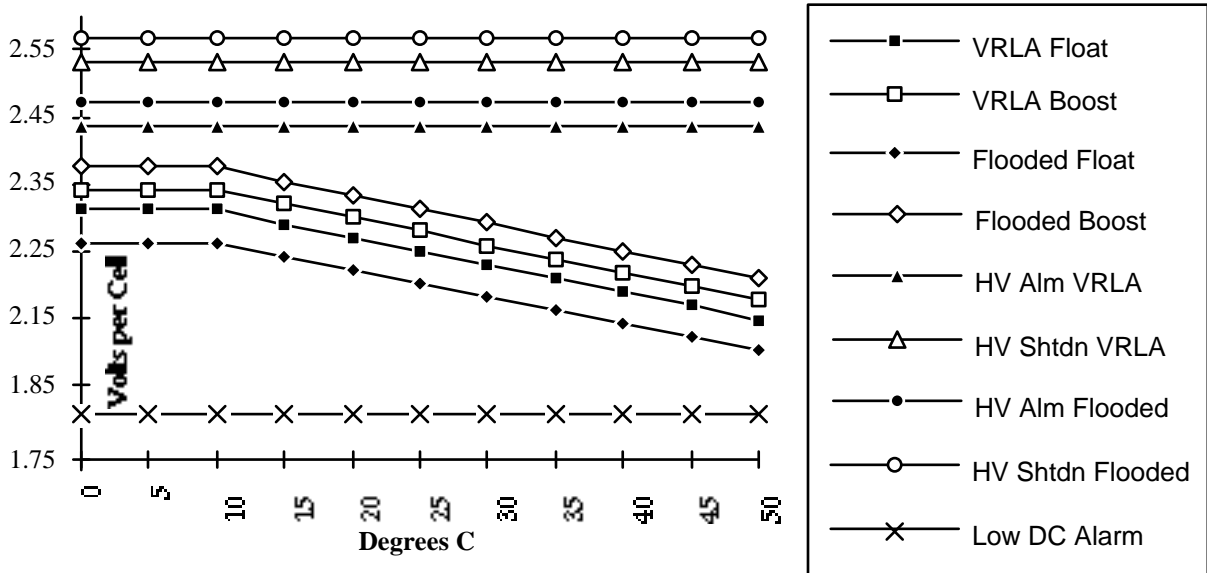

**4.3 Forced Load Sharing**

Chargers can be set up for forced load sharing when used in parallel with units of the same current rating. Forced load sharing causes the chargers to share the load from light loading to full load except when either charger is in BOOST mode (whether activated manually or via the AUTO BOOST system) or if either charger is operating in current limit. Chargers will share the load within  $\pm 10\%$  of each other.

To set up, ensure that the DC output leads from each charger are identical in length and wire gauge. Install a Load Share Cable (supplied by SENS or assembled by user) between terminals on both control boards where labeled "PAR".

To assemble a Load Share Cable:

1. Cut desired length of single wire (18 or 22 wire AWG).
2. Connect a 10K $\Omega$ , 2 Watts or more, resistor **inline** with signal wire. Connect resistor to wire using a Butt Connector or twist wires together and cover with Heat - shrink.

**5**  
**Trouble-**  
**shooting**

**5.1 Troubleshooting Table**

If there is a problem and you suspect the charger is at fault, turn off the AC mains supply before proceeding. Ensure that the following are correct: AC input wiring, battery and/or load connections

and PC card connectors. Ensure no foreign objects are in charger.

Symptom	Possible Cause	Test	Corrective Action
<b>No output / Charge Fail alarm</b>	Control board failure	Replace with known good board	Replace board,
	DC Fuse blown	Check fuse for continuity	Replace if open
	High DC Shutdown	Check LED D30 on control board	If lit, see "High output Voltage" under Symptom below in this chart
	Power rectifier circuit failure	Test all power diodes with meter, perform SCR test on all SCRs (figure 5.2)	Replace all shorted, open, or bad parts
	AC failure	Check input supply	Restore AC input supply
	Shutdown due to excessive output voltage	Check whether LED D30 on control board is lit	Shut off AC and DC breakers for at least 2 minutes, then restore
<b>AC breaker trips repeatedly</b>	Power diode, SCR, or freewheeling diode short	Check all power devices for shorts	Replace shorted device(s)
	<b>DC fuse blows or DC breaker trips</b>	Control board failure	Replace with known good board Replace board, send bad board to SENS for repair
	Freewheeling diode short	Check diode for short	Replace diode
<b>Low output voltage / Low DC alarm</b>	Control board failure	Replace with known good board	Replace board,
	Misadjusted Float Voltage pot (R34) on control board	Adjust pot and see if output voltage is affected	Adjust R34 to correct output voltage
	Overloaded charger	Turn off DC breaker, check voltage on INSIDE breaker terminals	Check load for problems, and check battery condition
	Overheating	Test all power diodes and SCRs (figure 5.2)	Replace bad devices
		Check for obstruction of top and bottom vents	Remove obstruction(s)
		Check for vertical mounting of charger	Mount charger vertically
		Verify that room temperature is less than 50 C	Reduce room temperature
		Verify that AC input voltage is not higher than charger's specified operating range	Contact utility company
		Check for failure of one phase	Contact electrician or utility company
	Bad filter capacitor	Disconnect capacitors one at a time and check for change in output voltage	Replace capacitor that corrected output voltage when removed
<b>Symptom</b>	<b>Possible Cause</b>	<b>Test</b>	<b>Corrective Action</b>

	Line voltage less than charger's specified operating range	Measure AC line voltage	Use larger gauge AC wires or contact utility company
<b>High output volts / High DC alarm</b>	Control board failure	Replace with known good board	Replace board
	Misadjusted Float Voltage pot on control board	Adjust pot and see if output voltage is affected	Adjust float pot to correct output voltage
	Remote temperature sensor failure	Remove Remote Temp. Sensor connector on control board J6	Replace Remote Temp. Sensor
<b>High ripple voltage</b>	Control board failure	Replace with known good board	Replace board,
	Excessive line voltage imbalance	Measure and compare the three AC phase voltages	Contact electrician or utility company
	Power diode / SCR failure	Test all power diodes with meter, perform SCR test on all SCRs (figure 5.2)	Replace all open or bad parts
	AC phase failure	Check for failure of one phase	Contact electrician or utility company
	AC line voltage too high	Check for AC line voltage over charger's specified operating range	Contact utility company
	Bad filter capacitor	Disconnect capacitors one at a time and check for change in output voltage	Replace capacitor that corrected output voltage when removed
<b>Alarms or indicators not functioning</b>	Alarm, display, or control board failure	Replace each board in turn with a known good board	Replace failed board(s)

**5.2 Component Diagnostic Tests**

Test #1: With transformer leads disconnected, energize the transformer with the normal AC supply voltage. Measure entire secondary voltage. It should be 1.1 times the nominal battery voltage.

Test #2: With one or both leads disconnected from the inductor, measure the resistance across the inductor terminals. If the resistance is near a short circuit condition, the inductor is OK.

Test #3: Power Diodes, units with SCR/diode modules

See the attached SCR/diode module troubleshooting table to determine module condition.

Test #3: Power Diodes, units with stud-mount diodes

Using a digital multimeter set to the diode testing function, measure the junction voltage across the diode. A reading of between 0.4 volt and 0.8 volt in the forward polarity direction and infinity in the reverse polarity direction indicates a good diode.

Test #4: SCRs, units with SCR/diode modules

See the attached SCR/diode module troubleshooting table to determine module condition.

Test #3: SCRs, units with stud-mount SCRs

Refer to Figure 5.2. Disconnect all the leads to the SCR and its heat sink. Connect a voltmeter across the 1KΩ resistor to measure the voltage drop. With the battery connected as shown, V<sub>drop</sub> should read approximately 2.3V (V<sub>source</sub>-0.7V). Remove the voltage source to the gate, but keep it connected to the 1KΩ resistor and cathode. V<sub>drop</sub> should equal zero. Reconnect the gate and reverse the batteries polarity. V<sub>drop</sub> should read zero volts. Readings other than these indicate a defective SCR.

Test #5: Due to the modest cost of the control circuit, we recommend that the entire unit be replaced rather than attempting to repair it. If the troubleshooting guide has not revealed any defective components (tests #1-4), the control circuit should be replaced as a unit.

Test #6: Remove all wires from the current shunt. Place a milliohmmeter across the two terminals. The following formula should be used to determine the correct resistance:

Resistance in ohms should equal  $0.5/\text{Output current rating of the charger}$ , except in 35 amp units when resistance should equal 0.1 ohms.

If the resistance is more than 20% too low, the current shunt should be replaced.

**FIGURE 5.2**  
**SCR test setup**

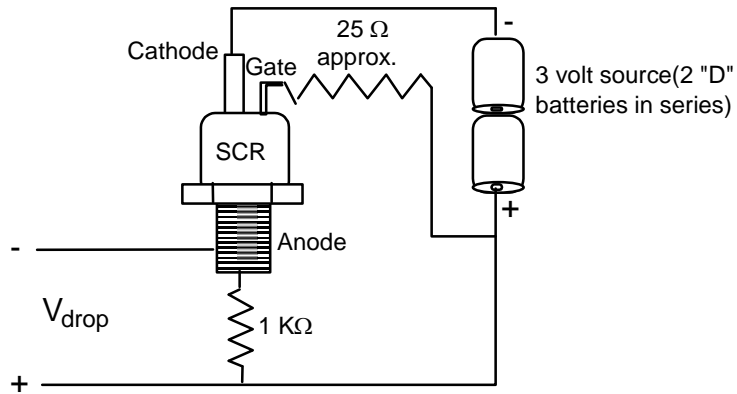

revisions				
ec #	ltr	description	date	app

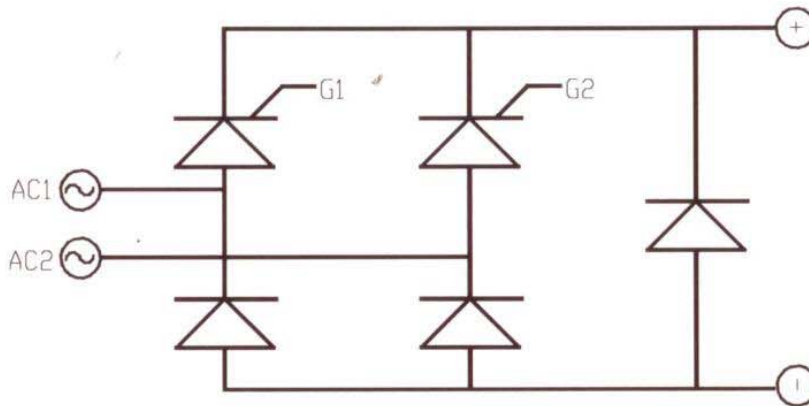
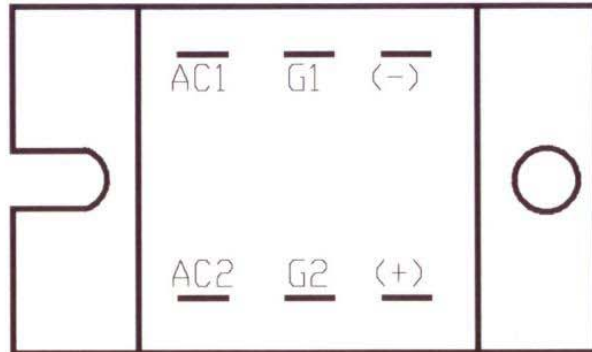

CHECKING POWER MODULES		
SET MULTIMETER TO SIEMANS SCALE (DIODE CHECK)		
TYPICAL READINGS		
MEASUREMENT	LEADS NORMAL	LEADS REVERSED
G1 TO (+)	10 - 50	10 - 50
G2 TO (+)	10 - 50	10 - 50
(+) TO (-)	.4 - .6	∞
AC1 TO AC2	∞	∞
AC1,2 TO (-)	.4 - .6	∞
AC1,2 TO (+)	.4 - .6	∞
G1 TO AC1	∞	∞
G2 TO AC2	∞	∞

		STORED ENERGY SYSTEMS LONGMONT, CO		
engineer: DM	description: RECTIFIER POWER MODULE			
drawn: AM	DIAGRAM & SCHEMATIC			
checked:	date: 10-30-97	code: 10	size: N/A	drwg. no. DIA\00483
DO NOT SCALE DRAWING				Rev. page: 1 of 1

Appendix

Diagram of Automatic Boost Operation (Optional Feature)

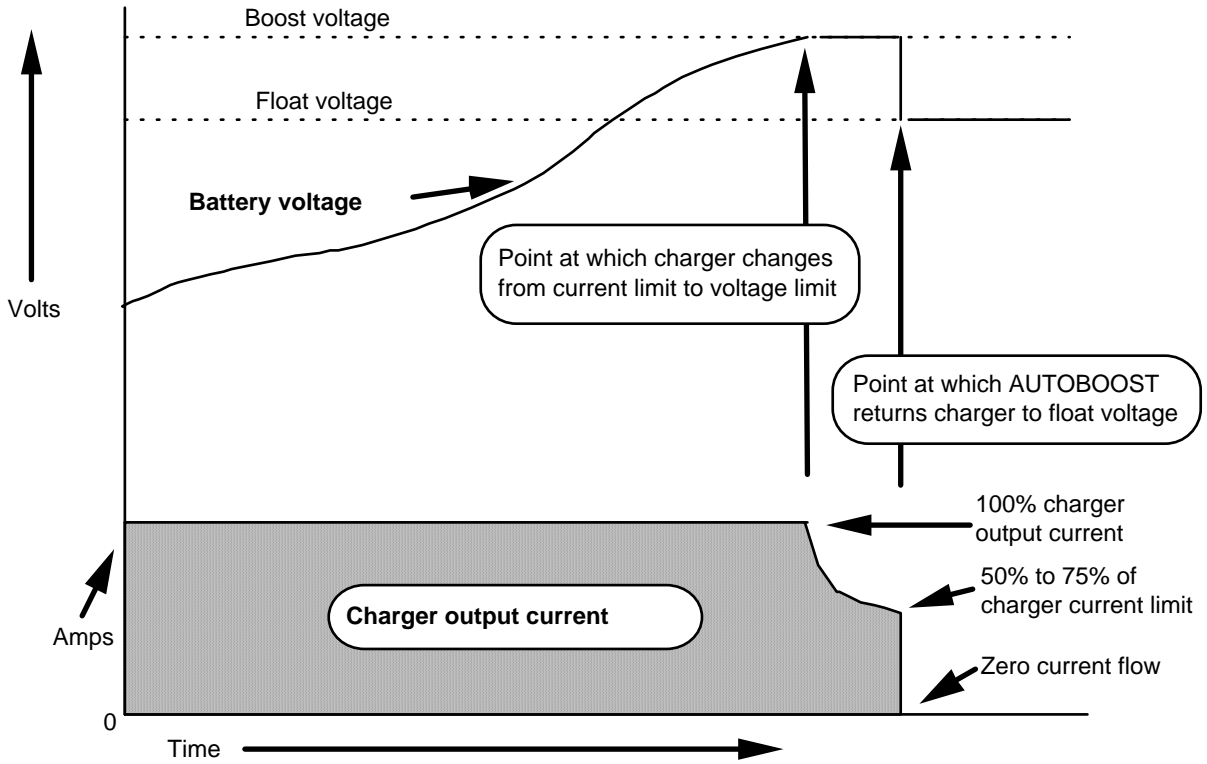

**NOTE:** When the charger switches from BOOST to FLOAT mode, no current will flow into the battery for a while due to the battery's high state of charge. **This is completely normal, and indicates that the charger is working properly.**

revisions				
ec #	ltr	description	date	app

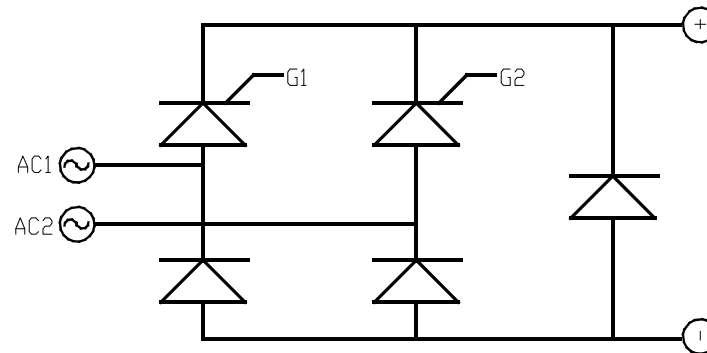
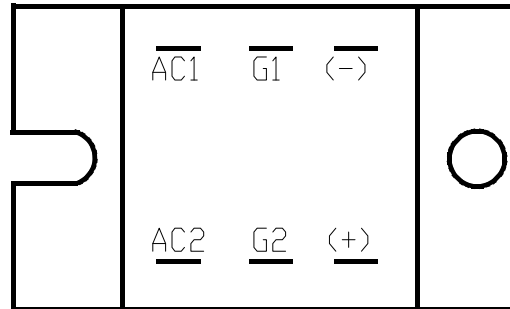

CHECKING POWER MODULES		
SET MULTIMETER TO SIEMANS SCALE (DIODE CHECK)		
TYPICAL READINGS		
MEASUREMENT	LEADS NORMAL	LEADS REVERSED
G1 TO (+)	10 - 50	10 - 50
G2 TO (+)	10 - 50	10 - 50
(+) TO (-)	.4 - .6	∞
AC1 TO AC2	∞	∞
AC1,2 TO (-)	.4 - .6	∞
AC1,2 TO (+)	.4 - .6	∞
G1 TO AC1	∞	∞
G2 TO AC2	∞	∞

**SENS** STORED ENERGY SYSTEMS  
LONGMONT, CO.

engineer: DM	description: RECTIFIER POWER MODULE DIAGRAM & SCHEMATIC		
drawn: AM			
checked:			
date: 10-30-97	code: 10	size: N/A	drwg. no: DIA\00483
DO NOT SCALE DRAWING page: 1 of 1			

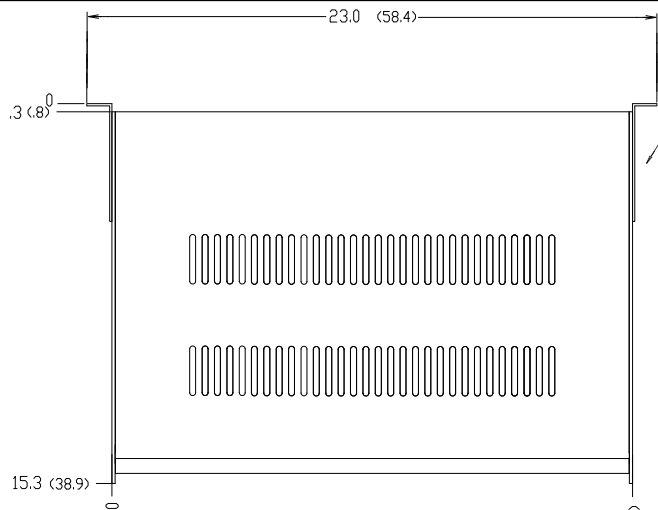

MOUNTING BRACKET SHOWN  
IN WALL MOUNTING POSITION

**NOTES TO INSTALLER:**

- 1) MAKE AC & DC POWER CONNECTIONS DIRECT TO AC & DC BREAKERS. LOCATION OF BREAKERS IS SHOWN.
- 2) MAXIMUM WIRE SIZE:  
AC: #4  
DC: #2/0
- 3) MAKE CONNECTIONS TO CHARGER FORM C ALARMS AT TERMINAL BLOCK ON A3. LOCATION OF TERMINAL BLOCK IS SHOWN. USE #16 TO #22 AWG WIRE.

TOLERANCES: UNLESS OTHERWISE SPECIFIED	ANGLES		PREPARED		AM	DESCRIPTION:		
			CHECKED			F3 DC3-A HOUSING		
			ENGINEER					
	FRAC. DEC.		DATE: 4-15-96	SIZE CODE TO NO. 10	DRAWING NO. DIA\00398		REV B	
		PART OF:	SCALE: N/A		SHEET: 1 OF 1			

**REVISIONS**

DCN	REV	DESCRIPTION	DATE	APP
102585	A	REMOVE KNOCKOUTS	11-5-98	AM
105174	B	CHNG REF FOR ALM BD A2 TO A3	6-05-06	HN

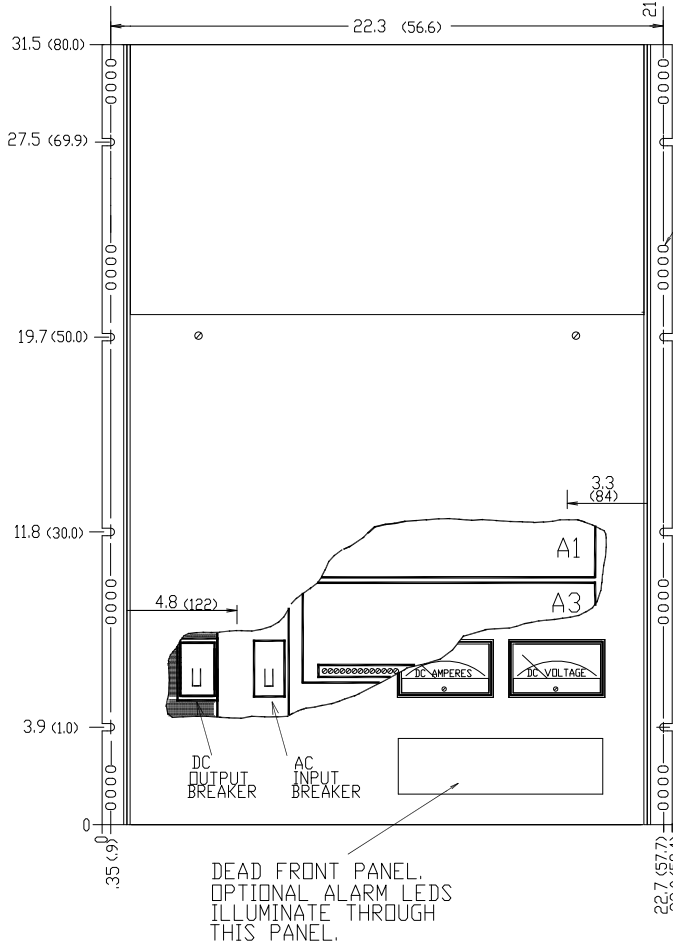

RACK MOUNTING HOLES - .41 X .25 OBLONGS  
16 EACH SIDE

WALL MOUNTING HOLES - .31 SLOTS  
4 EACH SIDE

DEAD FRONT PANEL.  
OPTIONAL ALARM LEDS  
ILLUMINATE THROUGH  
THIS PANEL.

MOUNTING BRACKET SHOWN  
IN WALL MOUNTING POSITION

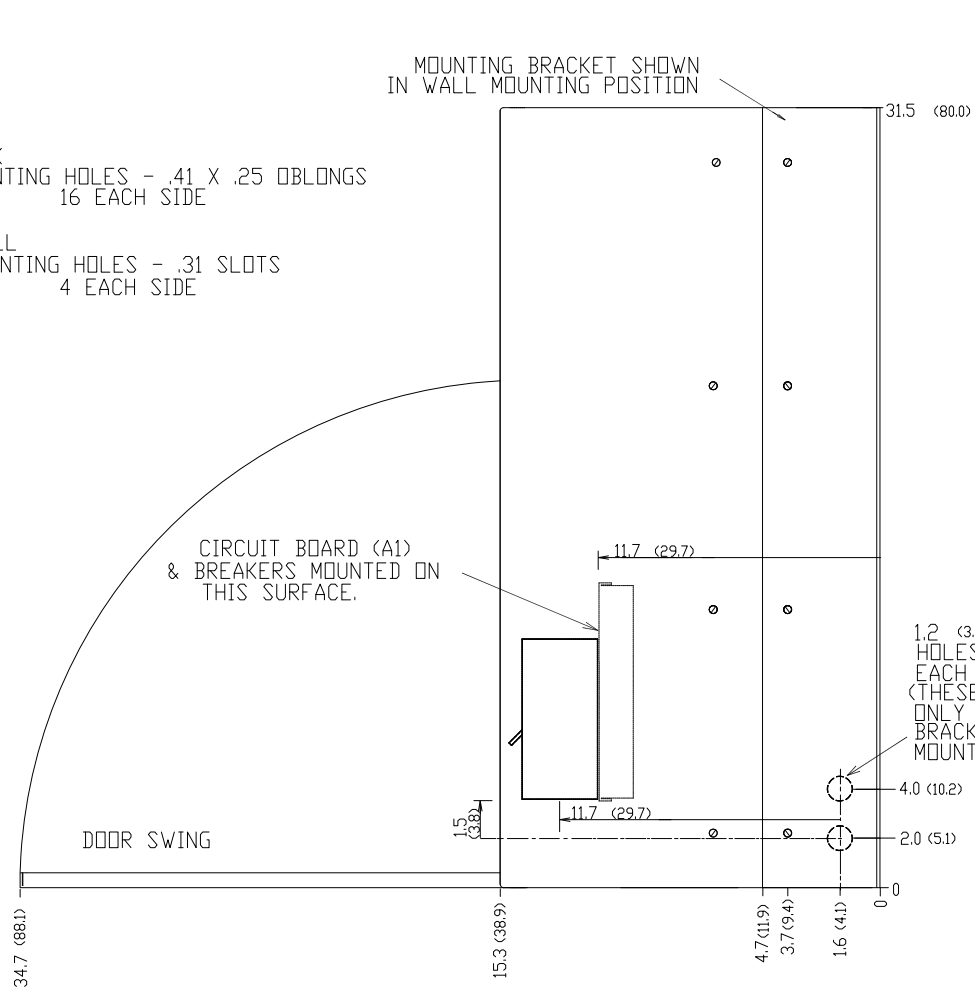

CIRCUIT BOARD (A1)  
& BREAKERS MOUNTED ON  
THIS SURFACE.

DOOR SWING

1.2 (3.0) DIAMETER  
HOLES LOCATED 2  
EACH SIDE.  
(THESE HOLES EXPOSED  
ONLY WHEN MOUNTING  
BRACKET IS IN RACK  
MOUNTING POSITION.)

		revisions	
ec #	tr	description	date
101957	A	CHG ORIENTATION OF PCA	7-16-97 AM

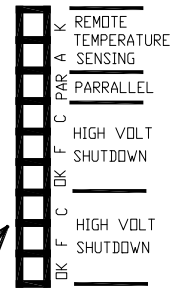

ALARM CONNECTIONS:

MAXIMUM WIRE SIZE-#16.  
SEE BODY OF USER GUIDE FOR COMPLETE EXPLANATION OF ALARM FUNCTION & CONNECTIONS.

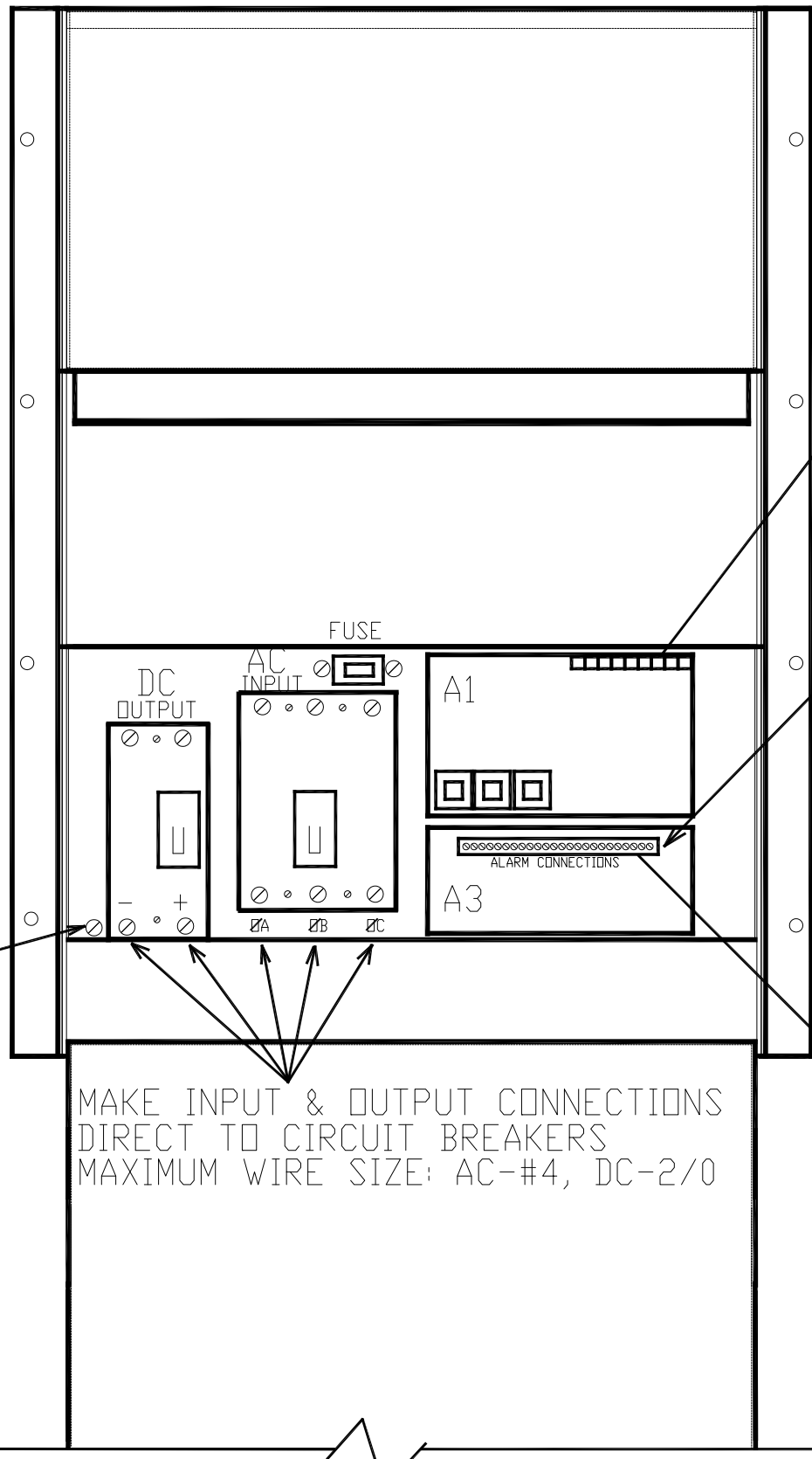

#10 STUD FOR GRND

MAKE INPUT & OUTPUT CONNECTIONS DIRECT TO CIRCUIT BREAKERS  
MAXIMUM WIRE SIZE: AC-#4, DC-2/0

tolerances (unless otherwise specified) Fract. dec. angles +1 +015 +1 +1	CONTRACT NO.	SENS STORED ENERGY SYSTEMS Longmont, CO	
	DRAWN	KAA	DATE
	CHECKED		
	DESIGN		
	DESIGN ACTIVITY		
CUSTOMER			
TITLE		F3 GENERIC AC BREAKER DC BREAKER	
SIZE	B	FSCM NO.	N/A
DWG NO.	DIA\00336		rev
			A
scale	none	release date	4-25-95
		sheet	1 OF 1