

**AUTOMATIC BEST BATTERY
SELECTOR**

INSTALLATION & OPERATION

BBS-1600

SENS part no:	101314
Document revision:	D
DCN No.	105788
Date	03/12/2010



1840 Industrial Circle
Longmont, CO 80501
Fax: (303) 678-7504
Phone(303) 678-7500
Email: service@sens-usa.com
Web: www.sens-usa.com

Installation or service questions? Call SENS at 1-800-742-2326 (303-678-7500) between 8 a.m. and 5 p.m. (Mountain Time) Monday through Friday, or visit our website.

IMPORTANT SAFETY INSTRUCTIONS FOR INSTALLER AND OPERATOR

1. **SAVE THESE INSTRUCTIONS.**

2. **DO NOT EXPOSE THIS PRODUCT TO RAIN OR SNOW.**

3. Use of an attachment not recommended or sold by SENS may result in a risk of fire, electric shock, or injury to persons.

4. **ONLY TRAINED AND QUALIFIED PERSONNEL MAY INSTALL AND SERVICE THIS PRODUCT.**

5. Do not operate the product if it has received a sharp blow, been dropped, or otherwise damaged in any way; shut off power at the branch circuit protectors and have the unit serviced or replaced by qualified personnel.

6. **WARNING: RISK OF EXPLOSIVE GASES.**

A. WORKING IN THE VICINITY OF A LEAD-ACID OR NICKEL-CADMIUM BATTERY IS DANGEROUS. STORAGE BATTERIES GENERATE EXPLOSIVE GASES DURING NORMAL BATTERY OPERATION. FOR THIS REASON, IT IS OF UTMOST IMPORTANCE THAT EACH TIME BEFORE USING THIS PRODUCT, YOU READ THIS MANUAL AND FOLLOW THE INSTRUCTIONS EXACTLY.

B. To reduce the risk of battery explosion, follow these instructions and those published by the battery manufacturer and the manufacturer of any equipment you intend to use in the vicinity of a battery. Review cautionary markings on these products and on the engine.

7. **PERSONAL PRECAUTIONS**

A. Someone should be within range of your voice or close enough to come to your aid when you work near a storage battery.

B. Have plenty of fresh water and soap nearby in case battery electrolyte contacts skin, clothing, or eyes.

C. Wear complete eye protection and clothing protection. Avoid touching eyes while working near a storage battery.

D. If battery electrolyte contacts skin or clothing, wash immediately with soap and water. If electrolyte enters eye, immediately flood the eye with running cold water for at least 10 minutes and get medical attention immediately.

E. **NEVER** smoke or allow a spark or flame in vicinity of battery or engine.

F. Be extra cautious to reduce risk of dropping a metal tool onto battery. It might spark or short circuit battery or other electrical part that may cause explosion. Using insulated tools reduces this risk, but will not eliminate it.

G. Remove personal metal items such as rings, bracelets, necklaces, and watches when working with a storage battery. A storage battery can produce a short circuit current high enough to weld a ring or the like to metal, causing a severe burn.

A
**Applicable
Drawings and
Documents**

<u>Drawing Description</u>	<u>Drawing number</u>
• Wiring Diagram	See Section C.6 below
• Mounting Hole Locations	See Section C.7 below

B
**System
Description**

B.1 General

The BBS-1600 automatic best battery selector is a diode isolator that connects two independent batteries to one or two starting motors (the load). The purpose of this isolation system is to allow current to flow from the battery in the best condition to the load, and to prevent a bad battery from discharging a good one. Current will be drawn approximately equally from both batteries if they are in a similar state of charge.

B.2 Features

- Automatic operation with no maintenance requirements
- Two high-current diodes with low forward voltage drop for high system efficiency
- Large aluminum heatsinks to ensure reliable cooling with no airflow
- ILSCO 4-barrel terminal block available for negative-lead connections
- Easy and convenient DC cable connection access via hinged front door
- Large size 2-inch conduit holes for ease of DC cable routing
- Integrated high-voltage transient protection devices [MOV's] for diodes
- Ground terminal lug, and front door ground strap for safety

C Installation

C.1 Wall Mounting

Mount the BBS-1600 on a suitable wall or bulkhead. See Section C.7 for mounting hole locations.

C.2 DC Cable Connections

Open the BBS-1600 front door, and make connections to the heatsinks and terminal block referencing Section C.6 or the wiring diagram located on the inside of the door. Make ring lug connections directly to each of the three heatsinks using the 5/16-18 hardware provided. An oxide inhibitor conductive grease should be applied to the metal surface contact areas of each heatsink and lug. **DO NOT PLACE ANY HARDWARE BETWEEN THE RING LUG AND HEATSINK. THE BOTTOM SURFACE OF THE RING LUG SHOULD MAKE A SOLID MECHANICAL AND ELECTRICAL CONNECTION TO THE HEATSINK.** The front door should always remain closed and latched during normal operation.

C.3 Terminal Definitions

- “+ INPUT A” and “+ INPUT B” - from positive battery terminals.
- “+ OUTPUT” - to one or two starters.

If needed:

- “- INPUT A” and “- INPUT B” - from negative battery terminals.
- “- OUTPUT” - to the negative side of the starters, or to common, or to frame for negative ground systems.

C.4 DC Cable Specifications

Use wire, connectors, and hardware in accordance with national and local codes;

- a. Gauge: up to 4/0 AWG (0000), stranded copper
- b. Temperature Rating: 90C minimum
- c. Style: THHN, RHH, RHHW, or SIS (typical)
- d. Length: 6 feet to source, 6 feet to load (24 feet total, round-trip) at specified voltage drop
- e. Conduit Holes: three provided (two input, one output), 2" trade size (meets NFPA 70 wire fill requirements for two 4/0 AWG insulated conductors).

C.5 Grounding

For system installations that require connection of the BBS-1600 enclosure to earth ground, use the ground lug installed inside the BBS-1600 on the rear panel. The ground lug accepts wire sizes #14AWG through #2AWG.

C
Installation
(Continued)

C.6 Wiring Diagram

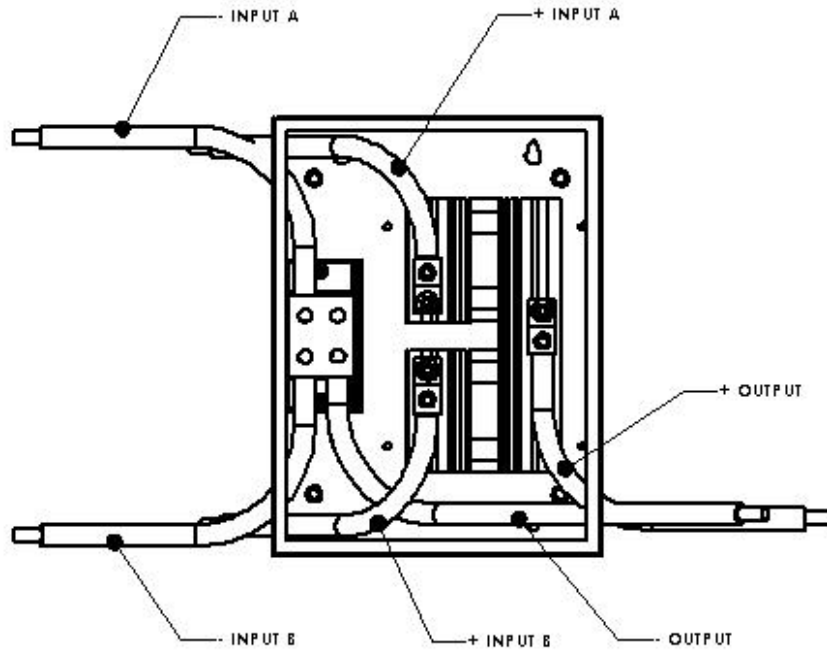

C.7 Mounting Hole Locations

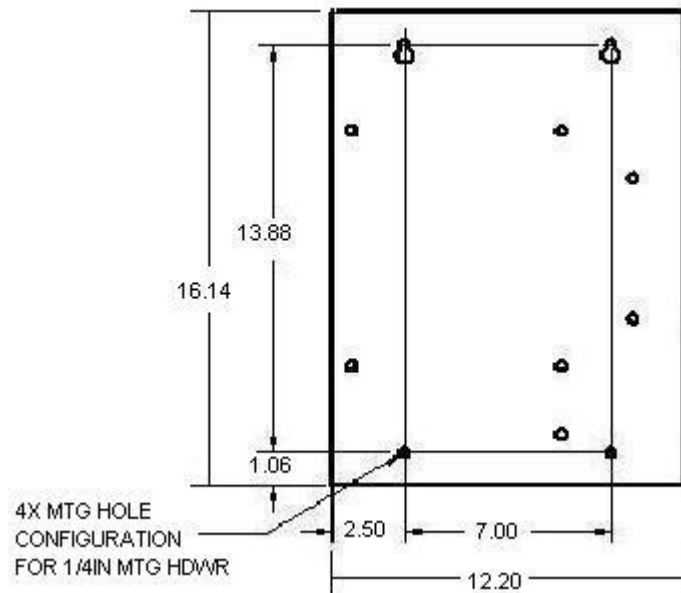

D Operation and Specifications

D.1 BBS-1600 Operation

The BBS-1600 operates automatically and without attention from the user. For continued operation within specification, DC cable connections should be periodically checked to assure that no hardware has loosened, and that all metal is free from corrosion.

D.2 Breakaway Current Specification

Maximum breakaway current (approximately 1 second at engine start-up) is 2,800Amps, with a maximum 2.0 volt drop as measured at the DC connections at the BBS heatsinks.

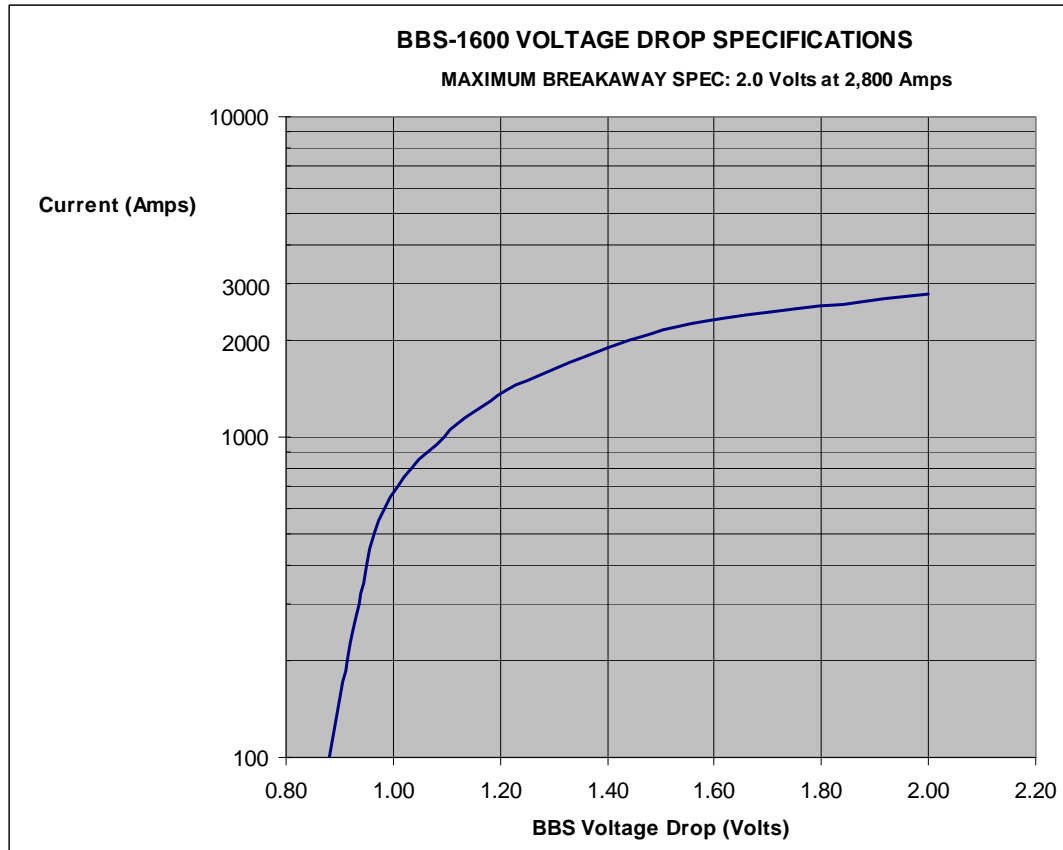

D.3 Rolling Current Specifications

See specifications in the table below, and also in a bar graph at the end of this manual.

Pulse Duration	Ambient Temperature	Rolling Current Specification
90 seconds	50C (122F)	1,050 Amps
	25C (77F)	1,250 Amps
	-18C (0F)	1,600 Amps
60 seconds	50C (122F)	1,350 Amps
	25C (77F)	1,600 Amps
	-18C (0F)	2,050 Amps
30 seconds	50C (122F)	1,600 Amps
	25C (77F)	2,200 Amps
	-18C (0F)	2,800 Amps
NFPA 110 15 on, 15 off 90 sec total	50C (122F)	1,600 Amps
	25C (77F)	2,200 Amps
	-18C (0F)	2,800 Amps

D
Operation and
Specifications
(Continued)

D.4 Continuous Current Specifications

The BBS-1600 may be operated in continuous current mode. Maximum continuous current specifications are as follows:

- 50 Amps DC continuous at 50C (122F) ambient temperature
- 60 Amps DC continuous at 25C (77F) ambient temperature
- 75 Amps DC continuous at -18C (0F) ambient temperature

D.5 Operating Voltage 0 to 120VDC Nominal

The BBS-1600 is rated for operation in DC systems up to 120VDC nominal, including battery systems that have actual DC system voltages that may be as high as 160 volts under certain operating conditions. The BBS-1600 is designed to operate reliably and safely in these types of systems.

D.6 Operation With an Engine-Driven Alternator

When a BBS is installed in an engine starting system with an engine-drive alternator, observe the following practices:

- For engine starting systems with a BBS, two battery stacks ("Battery A" and "Battery B"), and a dedicated battery charger for each battery stack, it may not be necessary to use an alternator
- For systems that require an alternator, the following configurations may be used:
 - (1) Connect one alternator to "Battery A" only
 - (2) Connect one alternator to "Battery B" only
 - (3) Connect one alternator to "Battery A" and a second alternator to "Battery B". It is important that "Battery A" & "Alternator A" are electrically isolated from "Battery B" & "Alternator B". This is necessary for proper BBS operation, which depends on two separate sides of the system and nothing such as an alternator to create a short across the BBS.**DO NOT CONNECT AN ALTERNATOR TO THE STARTER**

DO NOT CONNECT AN ALTERNATOR TO BOTH BATTERIES

D.7 Installation Questions or Failure(s)

Contact SENS at 1-800-742-2326, 8 a.m. - 5 p.m., (Mountain Time) Monday - Friday.

SENS BBS-1600 ROLLING CURRENT SPECIFICATIONS

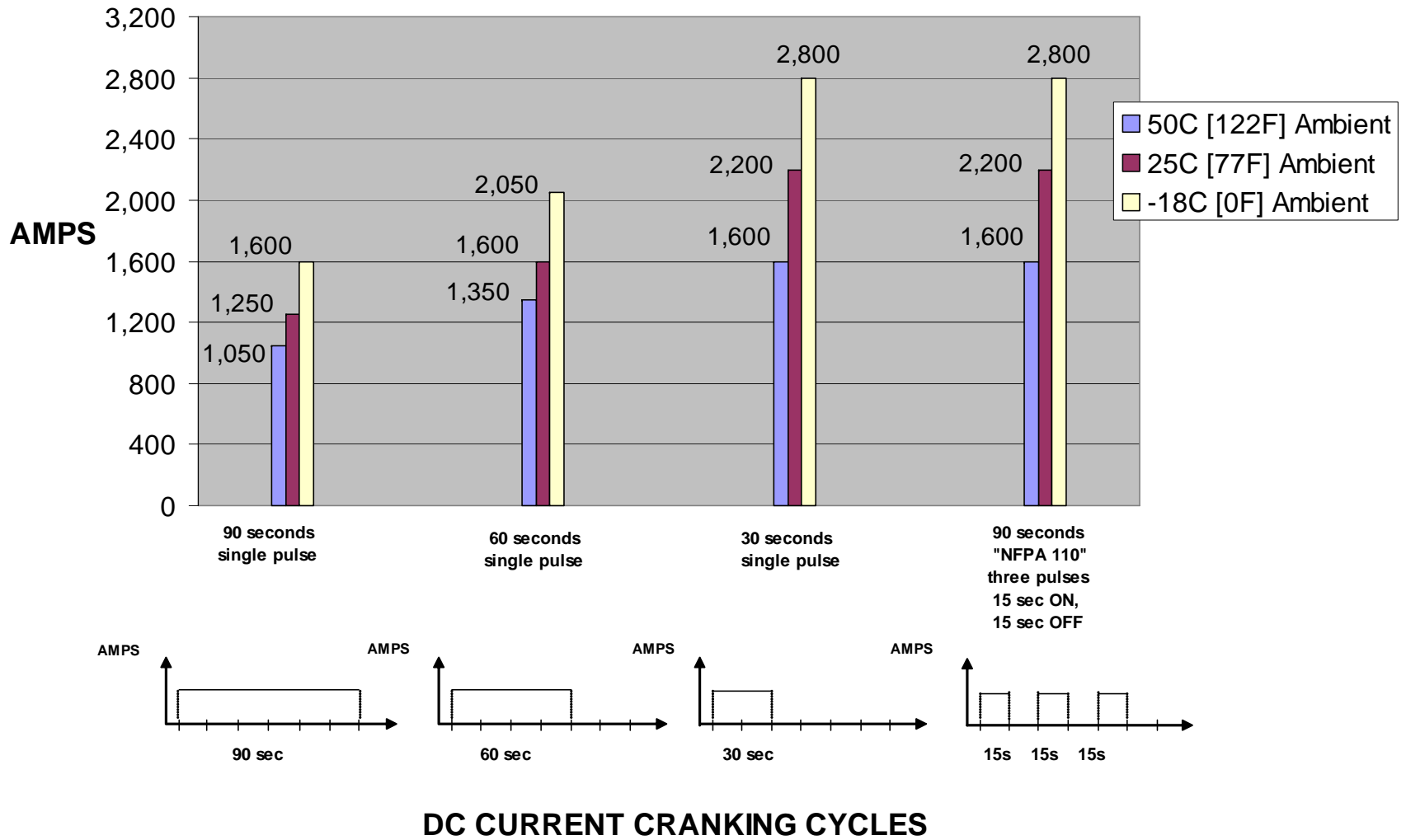

Copyright © Stored Energy Systems LLC 2010. Installation or service questions? Call SENS at 1-800-742-2326, 8am-5pm Mountain, M-F



SENS Limited Warranty Model ECU Chargers & BBS Best Battery Selectors

What is covered?

This warranty covers any defect in material and workmanship on ECU model battery chargers and BBS model best battery selectors manufactured by Stored Energy Systems, a Colorado Limited Liability Company (SENS).

What this warranty does not cover:

This warranty does not cover damages, defects or failures of your equipment resulting from shipping damage, accidents, installation errors, unauthorized adjustment or repair, unauthorized third-party service, failure to follow instructions, misuse, fire, flood, acts of persons not in our control, and acts of God.

For how long:

Three years from date of shipment.

What we will do:

If your battery charger or BBS is defective within three years of date of shipment, we will repair it or, at our option, replace it at no charge to you.

If we choose to replace your charger or BBS, we may replace it with a new or refurbished one of the same or similar design. The repair or replacement will be warranted for the remainder of the original three-year warranty period. If we determine that your charger or BBS cannot be repaired or replaced, we will refund its purchase price to you.

What we ask you to do:

Contact SENS service department to obtain warranty service instructions. To obtain warranty service the product must be returned, freight prepaid, to the factory under a Return Material Authorization (RMA) number provided by SENS. If, in SENS' opinion, the problem can be rectified in the field, SENS may elect to ship replacement parts for customer installation instead of having the product returned to the factory.

Limitation:

This warranty is limited to defects in material or workmanship of the product. It does not cover loss of time, inconvenience, property damage or any consequential damages. Repair, replacement or refund of the purchase price of the equipment is your exclusive remedy.