

1. HEIGHT AND WEIGHT OF SYSTEM MAY VARY, SEE SPECIFIC SYSTEM DETAILS.
2. TCP/IP (TRANSMISSION CONTROL PROTOCOL/INTERNET PROTOCOL) USES AN RJ-45 PORT TO ALLOW REMOTE UPDATES.
3. DOORS HAVE LOCKING LATCHES
4. LIFTING ACCOMPLISHED BY FORKLIFT OR PALLET JACK, OR BY LIFTING RINGS IF INSTALLED
5. ANCHORING REQUIRES QTY 4 MIN. 1/2 INCH ANCHORS INTO CONCRETE OR STEEL
6. MATERIALS POWDER COATED GALVANNEAL FOR CORROSION RESISTANCE - COLOR ANSI 61 GREY.
7. PANELS CAN BE REMOVED TO ADD HOLES FOR CONDUIT FITTINGS, SECURITY BIT NEEDED/INCLUDED TO REMOVE PANELS.

REV	DCN	DESCRIPTION	DATE	AUTHOR
A	108773	INITIAL RELEASE	11/15/2024	LMARCOON

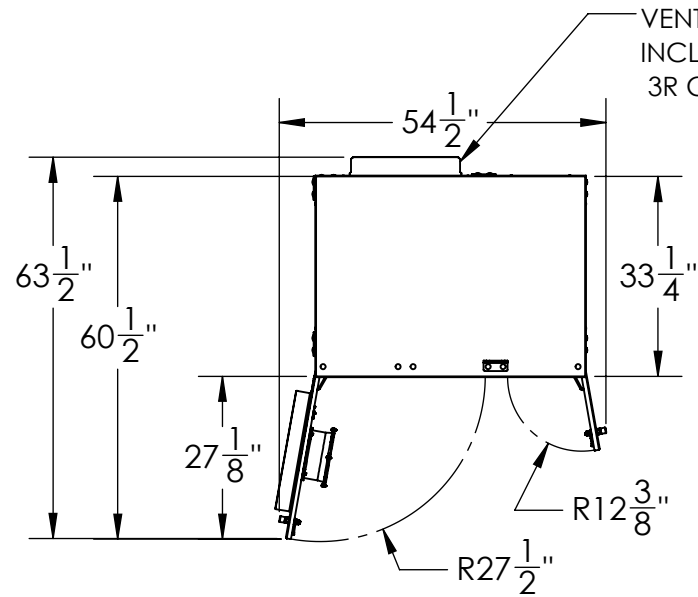

VENT HOODS ONLY INCLUDED WITH NEMA 3R CABINETS

OPTION FOR THERMAL MANAGEMENT FAN ON DOOR

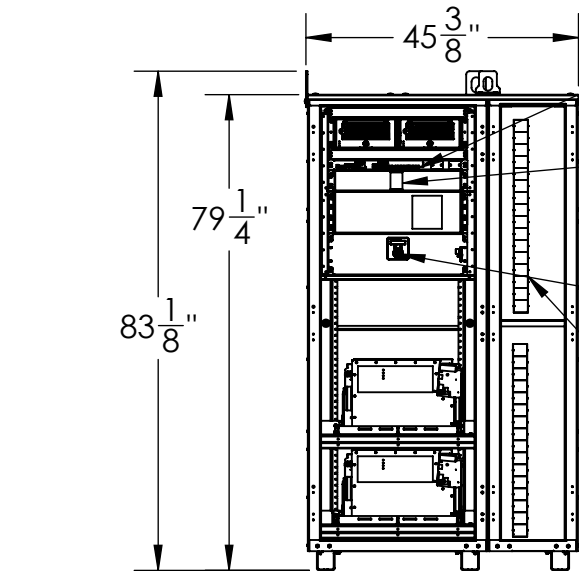
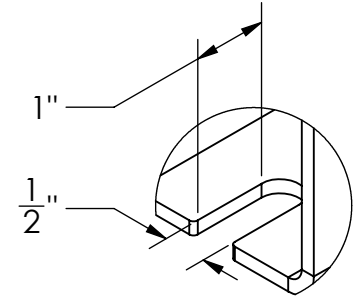
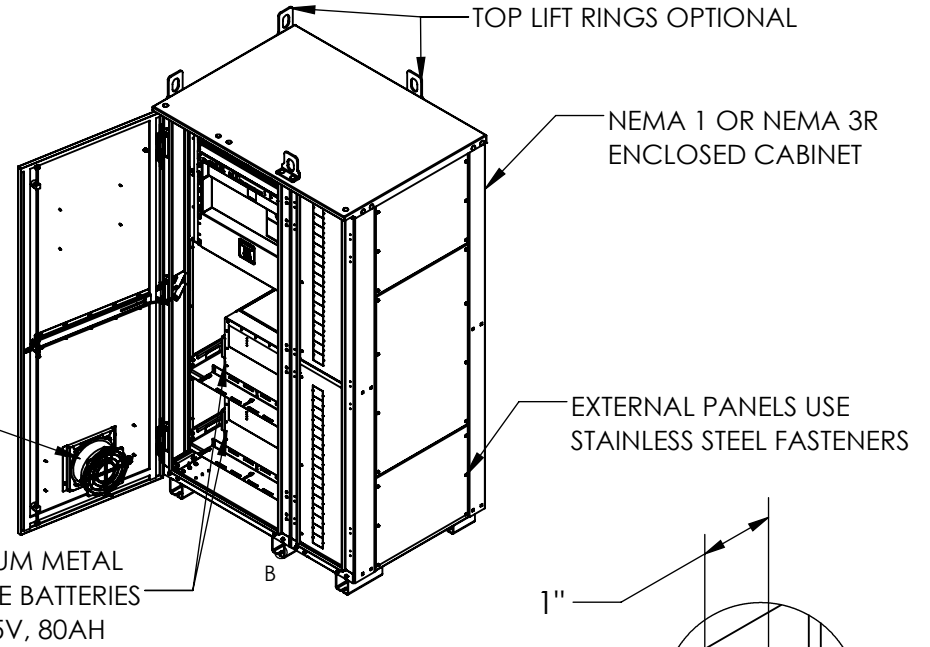

BATTERY MONITORING

CHARGER + BATTERY BREAKERS

USER INTERFACE

DC BRANCH CIRCUIT BREAKERS

ANCHOR MOUNTING PATTERN

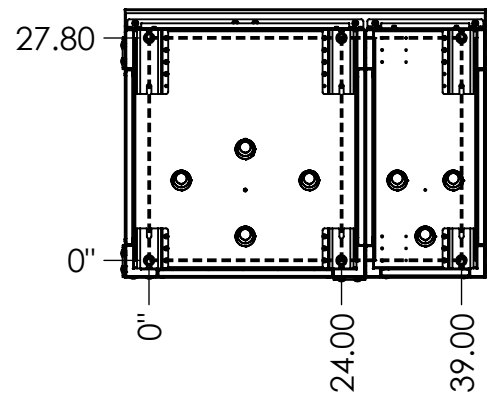

SENS
STORED ENERGY SYSTEMS
 1840 INDUSTRIAL CIRCLE LONGMONT, CO 80501
 303-678-7500 WWW.SENS-USA.COM

PROPRIETARY AND CONFIDENTIAL: THE INFORMATION CONTAINED IN THIS DRAWING IS THE SOLE PROPERTY OF STORED ENERGY SYSTEMS, LLC. ANY REPRODUCTION IN PART OR AS A WHOLE WITHOUT THE WRITTEN PERMISSION OF STORED ENERGY SYSTEMS, LLC, IS PROHIBITED.

UNLESS OTHERWISE SPECIFIED, FOR ALL SHEETS: DIMENSIONS ARE IN INCHES. DO NOT SCALE DRAWING. MOST REVISED ITEMS INDICATED IN BLUE.

DEFAULT TOLERANCES:

±1/16" ASSEMBLY TOLERANCE

PART NUMBER: 2DCAD-PC2-FH-SALT		REVISION: A
SHEET FORMAT SIZE: A	THIRD ANGLE PROJECTION	DESCRIPTION: F/H CABINET WITH 2 SALT BATTERIES, 2 CHARGERS
DIMENSIONS & TOLERANCES PER ASME Y14.5 - 2009		SHEET: 1 OF 1