

# Getting Started

# SuperTorque™ 8Z

Genset Starting System

THIS PRODUCT COVERED BY ONE OR MORE PATENTS: WWW.SENS-USA.COM/PATENTS

## Mounting

### Battery Shelf or Battery Box

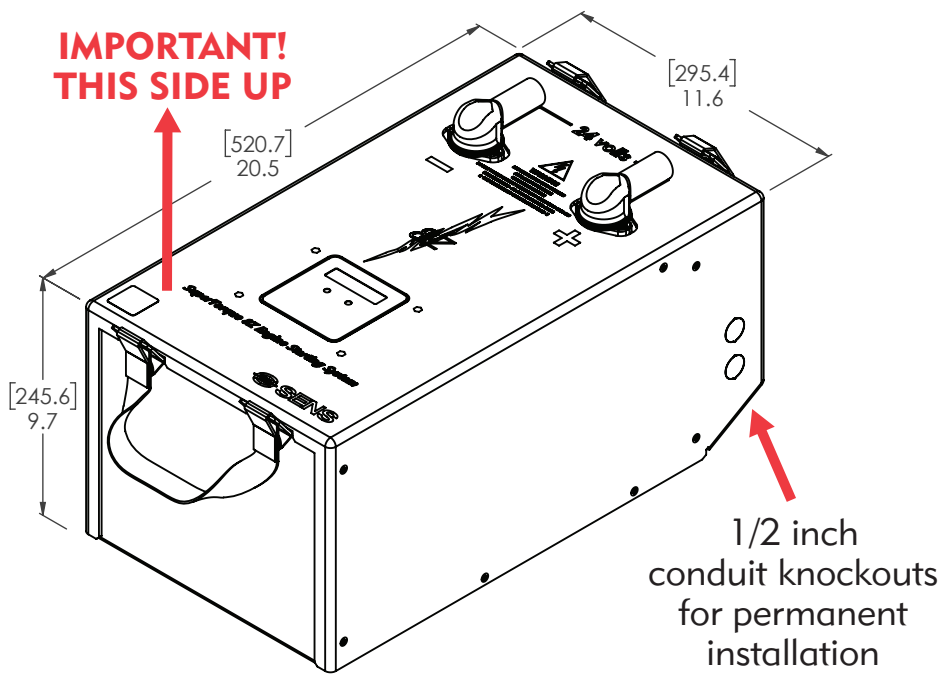

### Rigid Floor Mount

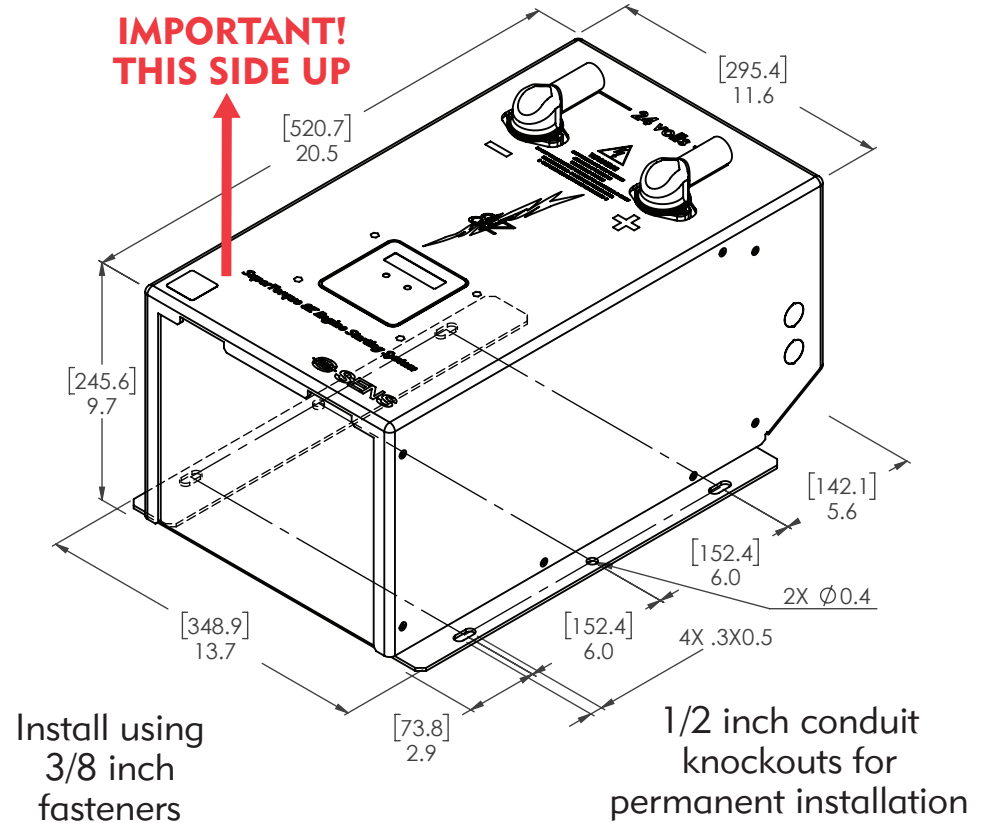

## Connections

Note - remove optional field cover to access connections

Connect **SENS SETUP UTILITY** using USB-C

Remove pluggable terminal block to connect **MODBUS RS-485** wires when optional display/comms PCA included (28-16AWG, tighten to 2lb-in, pin 1: +D1 (A), pin 2: -D0 (B), pin 3: COM, pin 4: Shield)

M/N: 8Z-XX-X-XX-B-X-X-XX  
M/N: 8Z-XX-X-XX-C-X-X-XX

To prevent battery discharge when AC power is not connected, press **"SLEEP"** button to turn off display and communications

Connect **J1939** network cable to RJ-45 connector when optional display PCA included (pin 1: Data High, pin 2: Data Low pin 8: COM)

M/N: 8Z-XX-X-XX-B-X-X-XX

Connect **MODBUS TCP/IP** network cable to RJ-45 connector when optional comms PCA included  
M/N: 8Z-XX-X-XX-C-X-X-XX

**SENSBUS** - connect load sharing units or remote accessories (**DO NOT** connect Ethernet, J1939, TCP/IP OR RS-485 here)

Remove pluggable terminal block to connect **ALARM RELAY** Form C contact wires (28-16AWG, tighten to 2lb-in, rated 30V AC/DC, 2A)

See unit label for factory alarm assignments, user configurable with SENS Setup Utility

Connect **DC 1/0AWG** minimum wires using ring lugs and M8 fasteners (13mm socket wrench, tighten to 60lb-in)

Optional - SAE battery terminal posts

**CAUTION:** voltage always present on battery terminals!

Press **"WAKE UP"** button to turn display and communications on when AC power is not connected

**WARNING:** this will cause battery discharge, connect ac power as soon as possible

Connect **AC INPUT** (100-240VAC, 50/60Hz) using 18-14AWG IEC 320 power cord ≤20A UL Listed Branch Circuit protection required, use UL recognized wire rated ≥90C

Optional - wire AC to screw terminal adapter provided with field termination kit (18-14AWG, tighten to 3.5lb-in)

Connect **AC OUTLET** (4A per unit) to load sharing units or SENS-approved external devices



# SuperTorque™ 8Z

## Genset Starting System

THIS PRODUCT COVERED BY ONE OR MORE PATENTS: WWW.SENS-USA.COM/PATENTS

## Installation/Operation

SuperTorque 8Z is a genset starting system including a high-performance NiZn battery, charging system, controls, communications, and user-interface in one package, specially targeted for long-life and high reliability.

- **Limited to indoor use: IP2X**
- **Battery voltage: 13V (12V systems) / 26V (24V systems) nominal, 15.2V/30.4V max, 80Ah standard, 90Ah ultra**
- **Recharge current: 15A, 0°C to 45°C; Discharge: 800A rolling current, 15s on, 15s off (-40°C to 45°C)**
- **Short Circuit Current: 5400A (80Ahr standard) / 6200A (90Ah ultra)**
- **Design Life: >15 years at 25°C**

- 1 - **Connect DC wires from 8Z to engine starter / DC bus**
- 2 - **Connect AC power to 8Z to start charging internal battery**
- 3 - **Connect communications wiring (optional)**
- 4 - **Use keypad (optional) to configure communications and view settings. Press up and down arrow keys to scroll through main menu options. Press left and right arrow keys to scroll through data available within each menu. Press center key to return to main menus.**
- 5 - **Charge for 8 hours minimum prior to placing into service or connecting in parallel**

**Output settings factory programmed. Attempt no adjustment.**

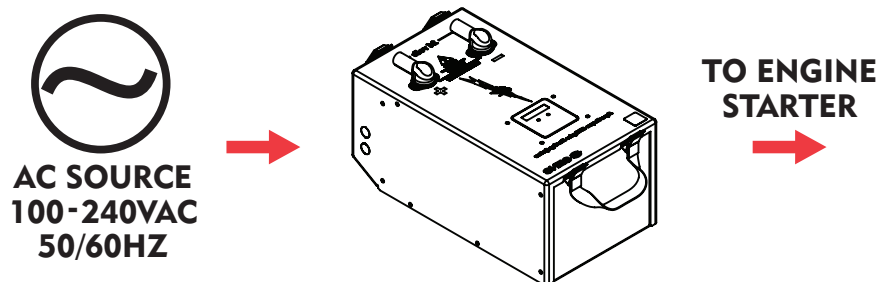

**Do not leave AC disconnected. To avoid battery damage, do not drain battery below 11.2VDC (12V nominal systems) or 22.4VDC (24V nominal systems).**

## IMPORTANT SAFETY INSTRUCTIONS

1. **SAVE THESE INSTRUCTIONS** –This guide contains important safety and operating instructions for SuperTorque 8Z genset starting system. Conserver ces instructions. Ce manuel contient des instructions importantes concernant la sécurité et le fonctionnement.
2. Use of an attachment not recommended or sold by the manufacturer may result in a risk of fire, electric shock, or injury to persons.
3. This genset starting system is intended for commercial and industrial use. ONLY TRAINED AND QUALIFIED PERSONNEL MAY INSTALL AND SERVICE THIS UNIT.
4. Do not operate genset starting system if it has received a sharp blow, been dropped, or otherwise damaged in any way; shut off power at the branch circuit protectors and have the unit serviced or replaced by qualified personnel.
5. To reduce risk of electric shock, disconnect the branch circuit feeding the genset starting system before attempting any maintenance or cleaning. Turning off controls will not reduce this risk.
6. **WARNING – RISK OF FIRE, EXPLOSION OR BURNS**
  - 6.1 **WORKING IN THE VICINITY OF A NICKEL-ZINC BATTERY IS DANGEROUS. BATTERY INCLUDES ALKALINE ELECTROLYTES. STORAGE BATTERIES GENERATE EXPLOSIVE GASES DURING NORMAL OPERATION. FOR THIS REASON, IT IS OF UTMOST IMPORTANCE THAT YOU READ THIS DOCUMENT AND FOLLOW THE INSTRUCTIONS EACH TIME YOU USE THE SYSTEM.**
  - 6.2 Do not disassemble battery, heat above 75°C, incinerate, puncture or impact. Mise en garde : Risque d'incendie, d'explosion ou de brûlures. Ne pas démonter, chauffer à plus de 75°C (ou °F) ou incinérer.
  - 6.3 To reduce the risk of battery explosion, follow these instructions and those published by the battery manufacturer and the manufacturer of any equipment you intend to use in the vicinity of a battery. Review cautionary markings on these products and on the engine. Pour réduire le risque d'explosion, lire ces instructions et celles qui figurent sur la batterie.
  - 6.4 Ensure battery spill control procedures exist in accordance with building, fire and installation codes
7. **PERSONAL PRECAUTIONS**
  - 7.1 Someone should be within range of your voice or close enough to come to your aid when you work near a storage battery.
  - 7.2 Have plenty of fresh water and soap nearby in case battery electrolyte contacts skin, clothing, or eyes.
  - 7.3 Wear complete eye protection and clothing protection. Avoid touching eyes while working near a storage battery.
  - 7.4 If battery electrolyte contacts skin or clothing, wash immediately with soap and water. If electrolyte enters eye, immediately flood the eye with running cold water for at least 10 minutes and get medical attention immediately.
  - 7.5 **NEVER** smoke or allow a spark or flame in vicinity of battery or engine. Ne jamais fumer près de la batterie ou du moteur et éviter toute étincelle ou flamme nue à proximité de ces derniers.
  - 7.6 Be extra cautious to reduce risk of dropping a metal tool onto battery. It might spark or short circuit battery or other electrical part that may cause explosion. Using insulated tools reduces this risk, but will not eliminate it.
  - 7.7 Remove personal metal items such as rings, bracelets, necklaces, and watches when working with a storage battery. A storage battery can produce a short circuit current high enough to weld a ring or the like to metal, causing a severe burn.
  - 7.8 **NEVER** charge a frozen battery. Ne jamais charger une batterie gelée.
  - 7.9 The charging circuit contains a DC output fuse for internal fault protection, but this will not protect the DC wiring from fault currents available from the battery. Consult national and local ordinances to determine if additional battery fault protection is necessary in your installation.
  - 7.10 Calculate arc flash for each module per NFPA 70e, annex D, method D.5, using bolted fault current (IBF) 5400A (80Ah) / 6200A (90Ah), 1/2 bolted fault current 2700A/3100A, protective device clearing time (max arcing time) 2s, max system voltage 30.4V, working distance 45.5cm and no protective device.
8. **PREPARING BATTERY FOR CHARGE**
  - 8.1 Storage - recharge every 6 months or when open circuit battery voltage drops below 13.5VDC (12V nominal systems) or 27.0VDC (24V nominal systems).
  - 8.2 Ensure area around battery is well ventilated and in accordance with local fire and installation codes while battery is being charged.
  - 8.3 Ensure battery terminals are clean and properly tightened. Be careful to keep corrosion from coming in contact with eyes.
  - 8.4 Do not operate genset starting system with damaged cables. Defective cables must be replaced before operation.
  - 8.5 Verify that all cables are properly secured and connected.
9. **INSTALLATION**
  - 9.1 Charging temperature: 0°C to 45°C.
  - 9.2 Do not tip, keep genset starting system level.
  - 9.3 Do not set anything on top of genset starting system.
  - 9.4 Unit shall be installed in accordance with Article 480 or 706 of NFPA 70 or Section 64 of CSA C22.1.
  - 9.5 Unit shall not be connected in series. Paralleled units are limited to two when using the AC outlet connection.
10. **SERVICE**
  - 10.1 Do not open genset starting system, not field servicable.
  - 10.2 Recommended Annual Maintenance - check all field wiring connections for electrical and mechanical integrity. Verify no corrosion or loose hardware is present.
  - 10.3 Contact Stored Energy Systems to dispose and recycle genset starting system.



For information and service on any SENS product, please contact us at:  
Sales 1.866.736.7872 • 303.678.7500 • Fax 303.678.7504 • www.sens-usa.com • info@sens-usa.com

Stored Energy Systems, LLC  
1840 Industrial Circle, Longmont, CO 80501 USA