

PowerCab2®

Factory-packaged Non-stop DC Power Systems



Installation & Operation Manual

SENS Part Number: 101343
Document Revision: C
DCN Number: 108766
Date: November 13th, 2024

This product is covered by one or more patents:
www.sens-usa.com/patents

Installation or service questions?
Call SENS between 8 a.m. and 5 p.m. (Mountain Time),
Monday through Friday, or visit our website.



1840 Industrial Circle
Longmont, CO 80501
Phone: 303.678.7500
800.742.2326
Fax: 303.678.7504
Email: service@sens-usa.com
Web: www.sens-usa.com

TABLE OF CONTENTS

1	IMPORTANT SAFETY INSTRUCTIONS FOR INSTALLER AND OPERATOR	4
2	PERFORMANCE SPECIFICATIONS	6
3	MOUNTING INSTRUCTIONS	10
3.1.	Mounting Location	10
3.2.	Mounting Instructions.....	10
3.3.	Optional Top-Lift Guidelines	10
4	SETUP AND WIRING	13
4.1.	Wire Ratings and Sizes	13
4.2.	Grounding Instructions and Connection	13
4.3.	DC Distribution Connection.....	13
4.4.	AC Connection.....	14
4.5.	Standard Alarm Connections	14
4.6.	High Current Relay Connections— <i>Optional</i>	16
4.7.	CANbus Connections.....	17
4.8.	RS-485 Connections	17
4.9.	Ethernet	18
4.10.	Service Connection.....	19
4.11.	Verify Connections	19
4.12.	Verify Covers	19
5	START-UP PROCEDURE	20
5.1.	Connect Battery	20
5.2.	Verify Configuration	20
5.3.	Apply AC Input Voltage	20
5.4.	Connect DC Distribution Outputs.....	20
5.5.	Power Off	20
6	ALARMS, LEDS AND DISPLAY	21
6.1.	LED Indicators.....	21
6.2.	Individual Alarm Relay Contacts.....	22
6.3.	LCD Panel	22
6.4.	Latched Alarms.....	22
6.5.	Alarm Definitions	22
7	OPERATION	28
7.1.	Charging Algorithms.....	28
7.2.	Float Mode	28
7.3.	Dynamic Boost™ Mode	28
7.4.	HELIX Mode.....	28
7.5.	Charging Low or Zero-volt Batteries	29
7.6.	Commissioning Batteries.....	29
7.7.	Battery Check.....	29
7.8.	Shunt Trip AC Breaker— <i>Optional</i>	29
7.9.	Restore Factory Defaults.....	30
7.10.	Keypad Operation	30
7.10.3.	Menu Options	31
7.11.	Configuration with SENS Setup Utility	37
7.12.	Protocol Communications Circuit Board	37
7.13.	Temperature Compensation	38
7.14.	Efficiency	39
8	SERVICE AND MAINTENANCE	40
8.1.	Recommended Annual Maintenance.....	40
8.2.	Power Module Access	40
8.3.	Air Filter.....	40
8.4.	Fans	40
8.5.	Supplemental Surge Protectors	40
9	MODBUS COMMUNICATIONS	41

9.1.	TCP/IP Modbus.....	41
9.2.	Modbus RS-485	41
9.3.	Modbus Holding Registers	42
9.4.	Basic Charging Alarms Bit Definition.....	43
9.5.	Charging Status Bit Definition	45
9.6.	Charging Alarms Extended Bit Definition	45
9.7.	Charging AC Alarms Bit Definition.....	46
9.8.	Accessory Channel Alarms Bit Definition	46
9.9.	Accessory System Alarms Bit Definition.....	46
9.10.	Accessory Assigned Channel Alarms Bit Definition	47
9.11.	Writable Control Flags (Coils) - Single coil writes: 0xFF00 for ON, 0x0000 for OFF	47
10	DNP3 COMMUNICATIONS—Optional	48
10.1.	TCP/IP DNP3.....	48
10.2.	RS-485 DNP3	48
10.3.	SENS DNP3 Config Tool	48
10.4.	Implementation Table.....	49
10.5.	Binary Inputs	50
10.6.	Binary Outputs	52
10.7.	Analog Inputs	53
10.8.	Analog Outputs	54
11	SODIUM NICKEL CHLORIDE (NACL) BATTERIES—Optional	55
11.1.	Installation, Removal and Replacement	55
11.2.	LED Indication	56
11.3.	Modbus TCP/IP.....	56
12	VALVE-REGULATED LEAD-ACID (VRLA) BATTERIES—Optional	62
12.1.	Installation, Removal and Replacement	62
12.2.	Battery Wiring	63
	LEAVE BATTERY TERMINAL PROTECTORS IN PLACE UNTIL JUST BEFORE ATTACHING A CABLE TO A TERMINAL. THIS ENSURES ONLY ONE TERMINAL IS EXPOSED AT ANY TIME.	63
13	TROUBLESHOOTING/ERROR CODES.....	64
13.1.	Reset Button.....	64
13.2.	Configuration Error Codes.....	64
13.3.	Troubleshooting Guide.....	65
14	GLOSSARY.....	72

1 IMPORTANT SAFETY INSTRUCTIONS FOR INSTALLER AND OPERATOR

- 1.1. **SAVE THESE INSTRUCTIONS** – This manual contains important safety and operating instructions for PowerCab2 DC backup systems.
- 1.2. Before using system, read all instructions and cautionary markings on battery charger, battery, and product using battery.
- 1.3. Use of an attachment not recommended or sold by the backup system manufacturer may result in a risk of fire, electric shock, or injury to persons.
- 1.4. **This backup system is intended for commercial and industrial use. ONLY TRAINED AND QUALIFIED PERSONNEL MAY INSTALL AND SERVICE THIS UNIT.**
- 1.5. Do not operate system if it has received a sharp blow, been dropped, or otherwise damaged in any way; shut off power at the branch circuit protectors and have the unit serviced or replaced by qualified personnel.
- 1.6. To reduce risk of electric shock, disconnect the branch circuit feeding the system before attempting any maintenance or cleaning. Turning off controls will not reduce this risk.
- 1.7. Use appropriate lockout / tagout procedures to ensure safety of all personnel installing and servicing this equipment. The AC, BATTERY and CHARGER breakers are equipped with provision to lock breakers in the OFF position.
- 1.8. **WARNING – RISK OF EXPLOSIVE GASES**
 - 1.8.1. **WORKING IN THE VICINITY OF A BATTERY IS DANGEROUS. STORAGE BATTERIES MAY GENERATE EXPLOSIVE GASES DURING NORMAL BATTERY OPERATION. FOR THIS REASON, IT IS OF UTMOST IMPORTANCE THAT YOU READ THIS MANUAL AND FOLLOW THE INSTRUCTIONS EACH TIME YOU USE THE CHARGER.**
 - 1.8.2. To reduce the risk of battery explosion, follow these instructions and those published by the battery manufacturer and the manufacturer of any equipment you intend to use in the vicinity of a battery. Review cautionary markings on these products and on the engine.
- 1.9. **PERSONAL PRECAUTIONS**
 - 1.9.1. Someone should be within range of your voice or close enough to come to your aid when you work near a storage battery.
 - 1.9.2. Have plenty of fresh water and soap nearby in case battery electrolyte contacts skin, clothing, or eyes.
 - 1.9.3. Wear complete eye protection and clothing protection. Avoid touching eyes while working near a storage battery.
 - 1.9.4. If battery electrolyte contacts skin or clothing, wash immediately with soap and water. If electrolyte enters eye, immediately flood the eye with running cold water for at least 10 minutes and get medical attention immediately.
 - 1.9.5. **NEVER** smoke or allow a spark or flame in vicinity of battery or engine.
 - 1.9.6. Be extra cautious to reduce risk of dropping a metal tool onto the battery. It might spark or short circuit the battery or another electrical part that may cause explosion. Using insulated tools reduces this risk but will not eliminate it.
 - 1.9.7. Remove personal metal items such as rings, bracelets, necklaces, and watches when working with a storage battery. A storage battery can produce a short circuit current high enough to weld a ring or the like to metal, causing a severe burn.

1.9.8. **When charging batteries, charge LEAD-ACID, LIQUID ELECTROLYTE NICKEL-CADMIUM, NICKEL-ZINC or SODIUM-CHLORIDE batteries only.** Consult SENS before using with any other type of battery or changing battery type from originally supplied with system - other batteries may burst and cause injuries to persons and damage to property. **NEVER** charge a frozen battery.

1.9.9. Consult national and local ordinances to determine if additional battery fault protection is necessary in your installation.

1.10. Preparing Battery For Charge

1.10.1. Be sure area around battery is well ventilated while battery is being charged.

1.10.2. Ensure battery terminals are clean and properly tightened. Be careful to keep corrosion from coming in contact with eyes.

2 PERFORMANCE SPECIFICATIONS

PowerCab2 factory-packaged non-stop DC power systems are specially hardened for use in harsh industrial environments. Advanced technology switch mode power conversion is significantly smaller & lighter than conventional line frequency (e.g. SCR) power conversion and, even without a battery connected, delivers lower output ripple and much faster dynamic response.

Forced Conduction™ cooling keeps the high efficiency power electronics free of dust and dirt, making PowerCab2 well-suited for operation in industrial, utility, power plant, and other harsh environments. Two variable speed, premium ball-bearing fans cool each rectifier. Rectifiers maintain nearly full output capability even if one fan fails. A fan failure alarm system with local and remote indication enables service dispatch while the second fan continues to run. The fan module is easily replaced in the field with common tools.

9 standard Form C contact alarms are factory set and field reconfigurable, with indication via communication port, front panel LCD and five assignable alarm relays. Four additional high current alarm relays are optional.

Options include various cabinet size/configurations, NEMA 3R ingress protection, fans, heaters, batteries, DC distribution breakers, supplemental surge suppression, and DNP3 data communications. Modbus data communications comes standard with each system. Systems can be equipped with multiple communication protocols. Specifications are detailed in the table below, see following sections for installation and operation instructions. Multiple systems can be housed in a single cabinet, allowing for full redundancy or dual AC feed systems.

Specifications

AC input	Voltage, frequency	Full output power: 358-528 VAC 3-phase line to line connected, 50% power limit from 188-357 VAC. 47-63 Hz.
	Input current	96A maximum at 358VAC (for maximum configured unit), see section 4.4
	Overcurrent protection	3-pole UL 489 listed circuit breaker
		25 kAIC standard, 65 kAIC optional, lockable. Two breakers optional for dual AC feed.
		Optional breaker status provides indication and alarm when the AC breaker is in open or tripped position
	AC transient protection	Optional breaker shunt trip provides input overvoltage damage protection by turning off breaker when the input voltage exceeds an adjustable level
		Layered electrical transient defenses. Optional UL1449 Type 1 Listed supplemental surge protection, alarmed and with field replaceable elements, surge capacity rated 75kA 8/20 μ s; visual and remote indications.
	Loss of phase	Continues operating with current limit reduced to 50%
	Efficiency	Up to 95%, see section 7.14
Power Factor & Total Harmonic Distortion	To 0.98 typical at maximum rated load current and boost charge voltage. Total Harmonic Distortion <3%.	
DC output	Voltage	120 VDC or 240VDC nominal. 120VDC: output adjustable from 8-160V. 240 VDC: output adjustable from 16-320V. If AC voltage is not applied, charger powers down below 60VDC.
	Current	120VDC output limit: 56kW or 400A, whichever is less. 240VDC output limit: 56kW or 200A, whichever is less.
	Soft Start	System gradually increases current with a maximum of 5 seconds to full-required output
	Charging modes	Multi-stage, including float, boost, HELIX and commissioning charge modes
	Current limit	100% current capability subject to temperature limits and AC voltage limits; field adjustable to max rated current

Charging characteristic	Constant voltage, current limited; patented Dynamic Boost and HELIX control																																
Line & load regulation	±0.5%																																
Output ripple	<30mV with battery, <100mV off-battery for 120VDC, <200mV off-battery for 240VDC. Delivers fast-responding, stable, well-filtered DC without battery.																																
Step response	8ms typical, to recover within 1% of rated output voltage from load step change of 50% rated output current																																
Output protection	Electronic current limit. 2-pole UL 489 listed charger feed and battery main circuit breakers.																																
	Output ≤200A: 10 kAIC standard, 25 kAIC optional. Output >200A: 50 kAIC standard, 100 kAIC optional. Lockable.																																
	Optional breaker status provides indication and alarm when the Charger breaker is in open or tripped position																																
DC distribution	Internal panel, 2-pole UL 489 circuit breakers, 22 or 34 positions																																
DC surge protection	Layered electrical transient defenses. Optional UL1449 Open Type 2 Listed supplemental surge protection, alarmed and with field replaceable elements, surge capacity rated 75kA 8/20 μs; visual and remote indications. Includes replaceable fuses, refer to separately provided diagrams.																																
Batteries	Optional, type lead-acid, NiZn or Sodium Nickel Chloride (NaCl, salt), 40-200Ah (varies based on battery type). Optional battery monitoring.																																
DC power supply operation	Delivers fast-responding, stable, well-filtered DC without battery																																
Battery temp. compensation	Standard. On-board sensor modifies output voltage when temperature is between 0°C and +40°C. Slope adjustable, factory set to – 0.18% per degree C. Optional remote battery monitor provides battery temperature probe.																																
Dead battery charge	Starts into and recharges zero-volt battery																																
Redundancy	Optional N+1 or N+2 redundancy provides more power modules than are required to meet the rated output. All modules will actively share the load up to the rated current of the system. Should a power module fail, each remaining module will equally share the connected system load and battery recharge demand.																																
Output blocking protection	Prevents sparking during battery connection or during hot swap operation																																
Output Derating	<table border="1"> <thead> <tr> <th rowspan="2">Input Voltage/# Phases</th> <th rowspan="2">% Output Power Available</th> <th colspan="3">Max. Available Output Current Per Module*</th> </tr> <tr> <th>140VDC</th> <th>60VDC</th> <th>30VDC</th> </tr> </thead> <tbody> <tr> <td>400-480VAC/3-ph</td> <td>Full Rating (7kW)</td> <td>50A</td> <td>50A</td> <td>50A</td> </tr> <tr> <td>400-480VAC/1-ph</td> <td>50% (3.5kW)</td> <td>25A</td> <td>50A</td> <td>50A</td> </tr> <tr> <td>208-240VAC/3-ph</td> <td>50% (3.5kW)</td> <td>25A</td> <td>50A</td> <td>50A</td> </tr> <tr> <td>208-277VAC/1-ph</td> <td>25% (1.75kW)</td> <td>12.5A</td> <td>29A</td> <td>50A</td> </tr> </tbody> </table> <p>*120V-50A shown, divide current values in half for 240V-25A modules</p>					Input Voltage/# Phases	% Output Power Available	Max. Available Output Current Per Module*			140VDC	60VDC	30VDC	400-480VAC/3-ph	Full Rating (7kW)	50A	50A	50A	400-480VAC/1-ph	50% (3.5kW)	25A	50A	50A	208-240VAC/3-ph	50% (3.5kW)	25A	50A	50A	208-277VAC/1-ph	25% (1.75kW)	12.5A	29A	50A
Input Voltage/# Phases	% Output Power Available	Max. Available Output Current Per Module*																															
		140VDC	60VDC	30VDC																													
400-480VAC/3-ph	Full Rating (7kW)	50A	50A	50A																													
400-480VAC/1-ph	50% (3.5kW)	25A	50A	50A																													
208-240VAC/3-ph	50% (3.5kW)	25A	50A	50A																													
208-277VAC/1-ph	25% (1.75kW)	12.5A	29A	50A																													
Auxiliary DC power supply	Optional, 12-48VDC, 300W, consumes one distribution breaker position																																
Auxiliary AC inverter	Optional, 120VAC 60Hz or 230VAC 50Hz, 600/1000/1100/2000/3000W options, consumes one distribution breaker position																																

Adjustment & Controls	Charge mode control	Fully automatic patented Dynamic Boost system. Manual boost, timed boost and battery commissioning options are available from front panel control.
	Front panel control	Change all parameters including voltages, current limits, alarm parameters, network configurations, time-outs, and more
	Computer adjustment	Change all parameters, troubleshoot, create/save configuration files for quick download to chargers using network connection and SENS Setup Utility software available at www.sens-usa.com
Status reporting	LEDs	Two multi-color front panel status LEDs
	Metering	AC/DC Voltmeter accurate to $\pm 1\%$; AC/DC ammeter to $\pm 1\%$; AC frequency meter to $\pm 1.5\%$; DC Output Watts; DC Output as a percent of maximum rated output
	Status display	20-character display of status & alarm messages
Alarms	Alarm Outputs	Factory set, field reconfigurable, latching and non-latching. Alarms available via communication port, alarm relays, and on LCD.
	Alarm Inputs	Two optional input contacts (via optional battery monitor) to monitor status of, and modify charger operation based on, external devices such as battery room fan or hydrogen monitor
	Alarm Form C contacts	Nine Form C contacts, rated 30V, 2A resistive, assignable. Up to four optional 120V, 5A resistive or 150VDC, 3A / 240VAC, 10A assignable.
	Pilot relay functions	Form C contacts configurable as pilot relays to switch external loads based on user-configurable conditions
Networking	Modbus	Modbus RS-485 on terminal blocks or TCP/IP on RJ-45 port
	DNP3	Optional DNP3 RS-485 on terminal blocks or TCP/IP on RJ-45 port
	SENSbus	Proprietary bus for connection of paralleled chargers and SENS accessories
Environmental	Operating temperature	-40°C to +70°C; full spec from -40°C to +50°C. Display may be unreadable and suffer reduced life above 65°C. Cold starts down to -40°C.
	Ingress protection	NEMA1/IP20 or NEMA3R/IP34
	System fan	Optional cabinet door fan, thermostat controlled, turns on at +40°C, includes replaceable fuses, refer to separately provided diagrams
	Heater	Optional cabinet heaters, keeps batteries above freezing
	Humidity	5% to 95%, non-condensing
	Altitude	0-6,500 ft (2,000 meters). Above this altitude, output is derated 0.012% per additional meter at rated ambient temperature.
	Vibration & shock resistance	EN60068-2-6, EN 60068-2-64 & EN 60068-2-27
	Electrical transient	ANSI/IEEE C62.41, EN 61000-4-12 on power terminals, IEC 61000-6-5 and ANSI/IEEE C37.90 (withstands 4kV line-to-line/line-to-earth without optional AC surge protection, 6kV or greater with optional AC surge protection)
Abuse protection	Reverse polarity	Charger self-protects without output protective device clearing. Indication via LED & LCD.
	Wrong voltage battery	Charger-battery voltage mismatch shuts down charger after 5 minutes. Indication via LED and LCD.
	Overvoltage shutdown	Selective; shutdown only operates if charger causes the overvoltage condition
	Overtemperature protection	Gradual output power reduction if heatsink temperature becomes excessive; recovery is automatic

Regulatory Compliance	North America	C-UL Listed for US & Canada: UL 508A
		NFPA-70, NEMA PE-5, PIP (optional)
		FCC Part 15, Class A commercial use and ICES-003 (Canada)
Construction	Housing	Floor mount; integrated key lock
	Housing material	Aluminum with powder coated finish or stainless steel
	Weight	Refer to separately provided system diagrams for weight information
	Cable entry	Rear, bottom or side access, refer to separately provided system diagrams
	Network/Alarm connections	Modbus: RJ-45 or terminal blocks 28 to 16 AWG. Form C alarms: 28 to 16 AWG.
	Power connections	AC breaker: 14 – 1/0AWG DC Distribution breakers: ≤20A: 14 – 10AWG. >20A: 10 – 1/0AWG.

3 MOUNTING INSTRUCTIONS

INSTALLATION OF THE UNIT MUST COMPLY WITH LOCAL ELECTRICAL CODES AND OTHER APPLICABLE INSTALLATION CODES AND BE MADE ACCORDING TO THE INSTALLATION INSTRUCTIONS AND ALL APPLICABLE SAFETY REGULATIONS.

Printed circuit boards contain static sensitive components. Damage can occur even when static levels are too low to produce a noticeable discharge shock. To avoid static discharge damage, handle circuit boards by the panel they are installed on only. Remove covers only when access is essential for installation and service and replace promptly when finished.

3.1. Mounting Location

See separately provided system diagrams for dimensions and mounting information.

- 3.1.1. System is rated NEMA1/IP20 or NEMA3R/IP34.
- 3.1.2. Charger will operate at full specification when located where temperatures are within -40°C (-40°F) to +50°C (122°F). Output power is gradually reduced at higher temperatures.
- 3.1.3. Leave clear space around all system ventilation openings.
- 3.1.4. The cabinet is intended to be floor mounted. The mounting surface must safely support the weight of the system and the fixed wiring.
- 3.1.5. Allow sufficient room for routing the fixed wiring to the system. All field connections wires enter the system from the rear, top or bottom.
- 3.1.6. Do not mount the system above any heat generating equipment or where it could get wet.

3.2. Mounting Instructions

- 3.2.1. Drill floor mounting holes and mount system using dimensions on separately provided system diagrams. Mounting hardware is not included with the system and must be provided by the installer.
- 3.2.2. Mount the system before connecting AC, DC, communications and alarm wiring to ensure unobstructed access to mounting holes.
- 3.2.3. Inspect the connections, busbars, and wiring for any loose debris or damage from installation.
- 3.2.4. Use all mounting points provided on the separately provided system diagrams.
- 3.2.5. Ensure all ventilation openings are clear and unobstructed.

3.3. Optional Top-Lift Guidelines

**WARNING:
LIFTING OF CABINET SHOULD ONLY BE PERFORMED BY TRAINED AND
QUALIFIED PERSONNEL**

3.3.1. Suggested Equipment

- Power lifting machine (crane, forklift, telehandler, etc.)
- Hooks/links required to connect lifting beam to lifting machine
- Tagline to control load while lifting
- Lifting beam ≥ 1200 mm wide and rated for ≥ 4000 lb
- An additional bail for center of lifting beam
- Six adjustable lifting chains with clevis hooks, 6 feet or 1800 mm minimum length, 4000 lbf

capacity per chain or higher

- Adjustable wrench/ratchet (minimum 28 mm) to loosen bolts to move/adjust bails

3.3.2. Preparation for Top-Lift

WARNING:

THESE INSTRUCTIONS ARE SUGGESTION ONLY. QUALIFIED INSTALLER MUST ASSESS THE EQUIPMENT AND PROCEDURE FOR THE SITE SITUATION AND DETAILS.

3.3.2.1. Cabinet Preparation

- 3.3.2.1.1. If not already installed, install batteries in cabinet, secure with locking brackets and screws as necessary.
- 3.3.2.1.2. If desired, pre-install system power cables, communication cables, and conduit hubs. Secure cables to prevent from inhibiting lifting and moving the cabinet.
- 3.3.2.1.3. Replace all cabinet panels and torque fasteners to 20 lb-in or 2.25 N-m or damage may occur.
- 3.3.2.1.4. Close and latch doors.
- 3.3.2.1.5. Detach crate and base pallet from cabinet feet.

3.3.2.2. Lifting Beam Preparation

- 3.3.2.2.1. Remove bolt/nut from included bails.
- 3.3.2.2.2. Re-position outer bails inward as needed for a final bail-to-bail distance of approximately the width of the cabinet plus an additional 6 inches on each side. See lifting diagram below.



- 3.3.2.2.3. Add the additional bail onto lifting beam to the right of center.

3.3.2.3. Lifting Preparation

- 3.3.2.3.1. Attach lifting beam to crane's hook.
- 3.3.2.3.2. Raise beam above the ground about 1 meter.

- 3.3.2.3.3. Route each chain through bails as shown in diagram above.
- 3.3.2.3.4. Use chain hooks on each chain to attach back to chain.
- 3.3.2.3.5. Adjust height by counting and selecting the link that holds the clevis hook just off the ground. Mark chain links as necessary.
 - 3.3.2.3.5.1. The four side chains should be equal length.
 - 3.3.2.3.5.2. The two center chain lengths will vary.
- 3.3.2.3.6. Raise beam over the cabinet.
- 3.3.2.3.7. Attach clevis hooks to the four outside rings on the cabinet.
- 3.3.2.3.8. Attach and adjust center chains for the two center rings. It may be necessary to lift the cabinet slightly to check and adjust length to the closest link.
- 3.3.2.3.9. Attach tagline through a cabinet foot as required.

4 SETUP AND WIRING

IMPORTANT! The system is configured at the factory and typically requires no adjustments before operating. Refer to the label on the inside front door for factory configured output and alarm relay assignments. The system may be reconfigured using the front panel keypad or by software programming using the SENS Setup Utility.

All wiring must comply with applicable codes and local ordinances. See separately provided system diagrams for access covers and conduit entry holes. Disconnect wires to remove covers as needed; do not hang covers from wires.

WARNING:

OPEN THE SYSTEM AC, CHARGER AND BATTERY BREAKERS TO ENSURE THAT AC AND BATTERY POWER ARE DISCONNECTED BEFORE WIRING THE SYSTEM

4.1. Wire Ratings and Sizes

- 4.1.1. All power conductors should be rated for use at 90°C or higher and 600V or higher. Alarm relay conductors and communications data cable should be rated for use at 75°C or higher.
- 4.1.2. Coordinate the AC input conductor size with the customer-provided feeder branch circuit protection device.

4.2. Grounding Instructions and Connection

- 4.2.1. System must be grounded to reduce risk of electric shock. The system must be connected to a grounded, metal, permanent wiring system, or an equipment-grounding conductor (earthing conductor) must be run with the circuit conductors and connected to equipment-grounding terminal on system.
- 4.2.2. Connect the equipment grounding conductor to the ground lug located inside the cabinet (see separately provided system diagrams for location). This lug is marked with the ground symbol. This should always be the first wire connected and the last wire disconnected. Tighten connections to torque specified below.

Ground Allowed Wire Gauge and Torque Requirements

Ground Connection Type	Allowed Wire Gauge	Required Torque	Tool
Barrel lug	14-2/0 AWG (2.5-70 mm ²)	14-10AWG: 35.0 In-Lb (3.95 Nm) 8 AWG: 40.0 In-Lb (4.52 Nm) 6-4 AWG: 45.0 In-Lb (5.08 Nm) 3 – 2/0 AWG: 50.0 In-Lb (5.65 Nm)	3/16 inch hex

- 4.2.3. Two holes for an optional chassis ground connection exist external to the cabinet on one foot. Connect ground cables using M6 or ¼ inch fasteners as desired. This connection is optional. The equipment ground lug provided internal to the system (described above) is still required whether this connection is used or not.
- 4.2.4. Per UL 508A, the negative output is grounded. Remove or modify the ground cable if a floating or positively grounded output is required. Systems are shipped with the ground fault alarm disabled; enable and configure the alarm setpoint using the front panel keypad or the SENS Setup Utility.

4.3. DC Distribution Connection

Ensure batteries are disconnected from DC bus. Connect the DC output conductors to the DC output distribution breakers in the system. Always observe proper polarity of the DC output leads. DC distribution breakers accept 14AWG – 10AWG wire for ≤20A and 10AWG – 1/0AWG wire for >20A. Tighten connections to torque specified on breakers. Connect DC distribution ground wires to the ground bar provided near the breakers; ground bar accepts 14 – 4AWG wire. Route DC wiring at least ¼ inch (6 mm) away from AC wiring and alarm wiring. See separately provided system diagrams for more details and breaker handles for output

breaker current ratings.

Per UL 508A, the negative output is grounded. Remove or modify the ground cable if a floating or positively grounded output is required.

4.4. AC Connection

This unit is to be permanently connected to the AC circuit and to the battery. The unit is rated to operate at full power on any 3-phase AC input within the range of 358-528VAC, 47-63Hz. The unit is rated to operate at 50% power from 188-357VAC, 47-63Hz.

Ensure that the AC input supply is de-energized. Connect the AC line conductors to the AC input breaker in the system. AC breaker accepts 14 – 1/0AWG wire. Tighten connections to torque specified on the breaker. Connect ground wire to the ground bar provided near the breaker; ground bar accepts 14 – 4AWG wire. Route AC wiring at least ¼ inch (6 mm) away from DC wiring and alarm wiring. See separately provided system diagrams for more details and breaker handle for input breaker current rating. See product label on inside front door for input current rating. Note that the input current conductors and feeder protection must be sized according to the input current shown on the product label.

4.5. Standard Alarm Connections

See label on inside of system door for original factory alarm relay assignments. Alarm relay assignments are custom configurable using the SENS Setup Utility. Alarm circuits are rated 2A at 30V AC or DC. Connect alarm wiring to the respective terminals on the pluggable terminal block. To make wiring easier, the terminal block unplugs from its header. Pull terminal block straight out from header to remove. Connect wires to terminal block by tightening screws at each position. After wires are connected, plug terminal block securely back into header. Wire from FAIL or OK to COM depending on whether the alarm should be present on an open or closed circuit (see table below). Connect alarm terminals only to low voltage, limited energy (“Class 2”) circuits. The terminals accept 28-16 AWG (0.08-1.5 mm²) conductors. Tighten connections to 2.0 Lb-In (0.22 Nm) using a small slotted driver. Route alarm wiring at least ¼ inch (6 mm) away from DC wiring and AC wiring. P-clamps provided with system (see envelope inside cabinet) to install and route alarm wiring as desired.

Standard Alarm Connections

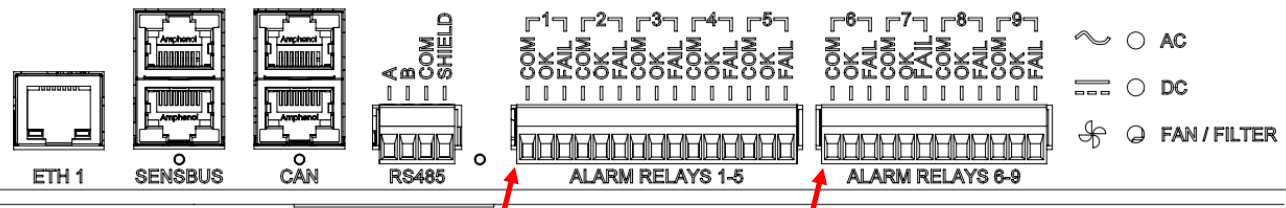

PULL TO REMOVE FROM HEADER

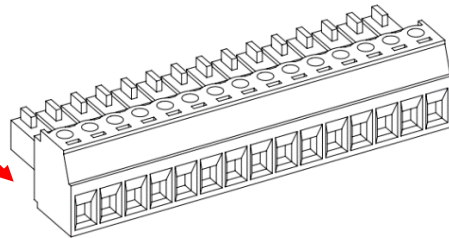

**9 RELAYS,
3 POSITIONS PER
RELAY:
COM, OK, FAIL**

Typical Alarm Relay Contact Wiring for Stationary Power Configuration

Wire from COM to OK for alarm present on open circuit or from COM to FAIL for present on closed circuit.

	RELAY 1 Non-latching Coil	RELAY 2 Non-latching Coil	RELAY 3 Latching Coil	RELAY 4 Latching Coil	RELAY 5 Latching Coil
Relay Contacts	Summary Alarm*	AC Fail and Charger Fail	Battery Discharging Alarm	High DC Alarm	Low DC Alarm
Common	COM (TB1-1)	COM (TB1-4)	COM (TB1-7)	COM (TB1-10)	COM (TB1-13)
Open on alarm	OK (TB1-2)	OK (TB1-5)	OK (TB1-8)	OK (TB1-11)	OK (TB1-14)
Close on alarm	FAIL (TB1-3) Defaults to FAIL with no AC and DC power (normally closed)	FAIL (TB1-6) Defaults to FAIL with no AC and DC power (normally closed)	FAIL (TB1-9)	FAIL (TB1-12)	FAIL (TB1-15)

	RELAY 6 Latching Coil	RELAY 7 Latching Coil	RELAY 8 Latching Coil	RELAY 9 Latching Coil
Relay Contacts	Summary Alarm*	Assignable	Assignable	Assignable
Common	COM (TB2-1)	COM (TB2-4)	COM (TB2-7)	COM (TB2-10)
Open on alarm	OK (TB2-2)	OK (TB2-5)	OK (TB2-8)	OK (TB2-11)
Close on alarm	FAIL (TB2-3)	FAIL (TB2-6)	FAIL (TB2-9)	FAIL (TB2-12)

*Summary alarm includes AC Fail, Charger Fail, Battery Discharging, High DC and Low DC alarms.

Functions and operation assigned to each relay are typical. Different functions and assignments are available both from the factory and by reassignment using the SENS Setup Utility.

4.6. High Current Relay Connections—Optional

Optional high current relay assignments are custom configurable using the SENS Setup Utility. There are two high current alarm relay options available from the factory. The first variant of alarm circuits (2) is rated 5A at 120VAC. The second variant of alarm circuits (2) is rated 3A at 150VDC and 10A at 240VAC. Connect optional alarm wiring to the respective terminals on the pluggable terminal block. To make wiring easier, the terminal block unplugs from the header. Pull terminal block straight out from header to remove. Connect wires to terminal block by tightening screws at each position. After wires are connected, plug terminal block securely back into header. Wire from FAIL or OK to COM depending on whether the alarm should be present on an open or closed circuit (see table below). The terminals accept 26-12 AWG (0.14-4.0 mm²) conductors. Tighten connections to 5.5 Lb-In (0.62 Nm) using a small slotted driver. Route alarm wiring at least ¼ inch (6 mm) away from DC wiring and AC wiring. P-clamps provided with system (see envelope inside cabinet) to install and route alarm wiring as desired.

Optional High Current Relay Connections

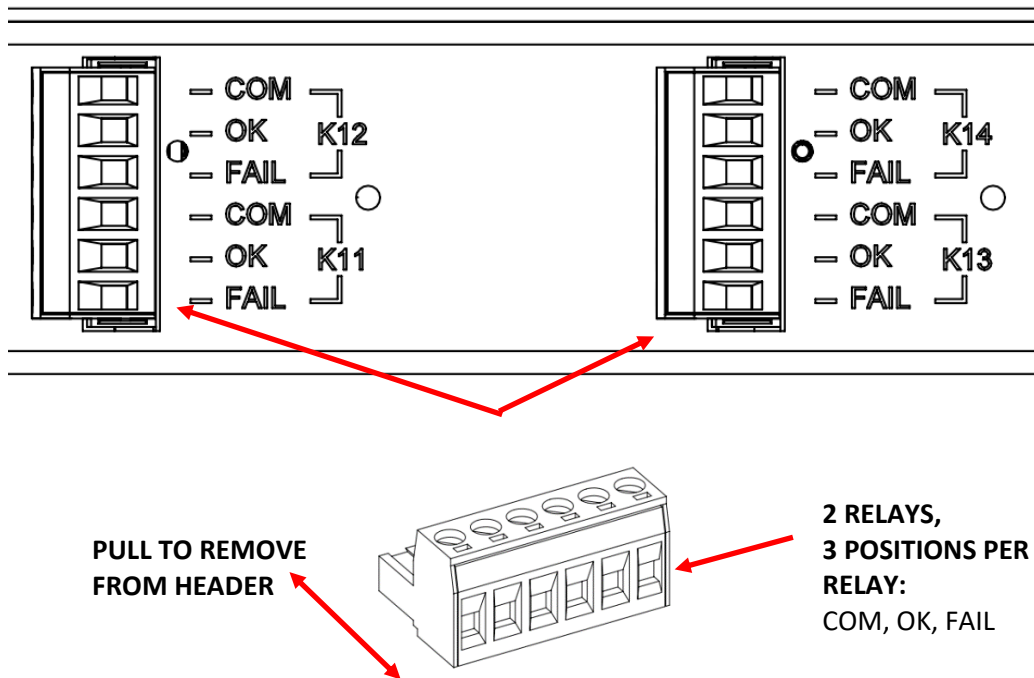

Optional High Current Relay Connections

Wire from COM to OK for alarm present on open circuit or from COM to FAIL for present on closed circuit.

	RELAY 11 Non-latching Coil	RELAY 12 Non-latching Coil	RELAY 13 Non-latching Coil	RELAY 14 Non-latching Coil
Relay Contacts	Assignable	Assignable	Assignable	Assignable
Common	COM (TB3-3)	COM (TB3-6)	COM (TB4-3)	COM (TB4-6)
Open on alarm	OK (TB3-2)	OK (TB3-5)	OK (TB4-2)	OK (TB4-5)
Close on alarm Defaults to FAIL with no AC and DC power (normally closed)	FAIL (TB3-1)	FAIL (TB3-4)	FAIL (TB4-1)	FAIL (TB4-4)

4.7. CANbus Connections

Every system includes CANbus via two RJ-45 jacks. The ports are in parallel and either port may be used. See table below for connector pinout. Communications are isolated. This interface is intended for communication with customer devices including battery monitoring systems, user interfaces, and customer-specific CAN protocol communications. Consult the factory for configuration and setup.

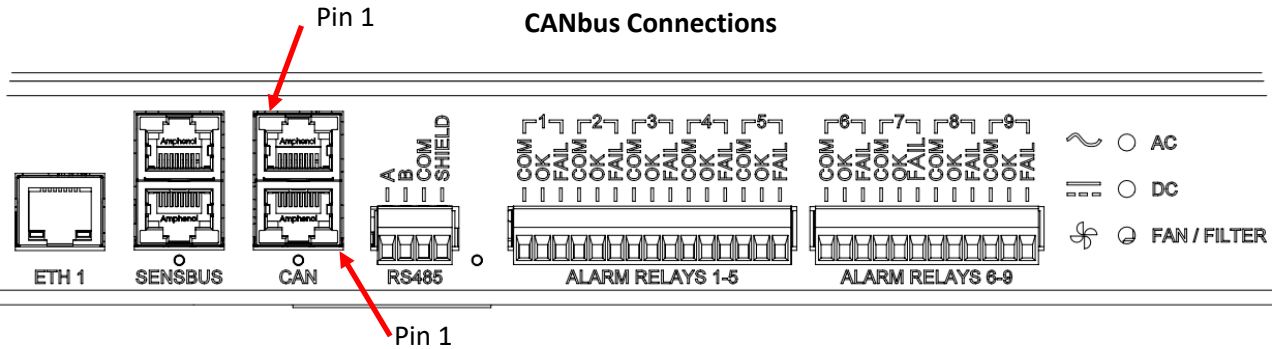

Connector Pinout

Pin #	Purpose
1	CANbus
2	CANbus
3	No connect pass-through
4	No connect
5	No connect
6	No connect pass-through
7	Power*
8	Common (isolated)

*Main circuit PCA only, used for interconnect between SENS devices

4.8. RS-485 Connections

Every system includes RS-485 connections via a 4-pin pluggable terminal block. This interface is intended for monitoring and communicating with the system. Available protocols include Modbus (standard on all systems) and DNP3 (optional). Use connector position A for Modbus +D1 and position B for Modbus -D0. The terminals accept 26-12 AWG (0.14-4.0 mm²) conductors. Tighten connections to 5.5 Lb-In (0.62 Nm) using a small slotted driver. Route alarm wiring at least ¼ inch (6 mm) away from DC wiring, AC wiring, low voltage wiring, and the circuit board. P-clamps provided with system (see envelope inside cabinet) to install and route alarm wiring as desired. See manual sections on specific protocols for more information.

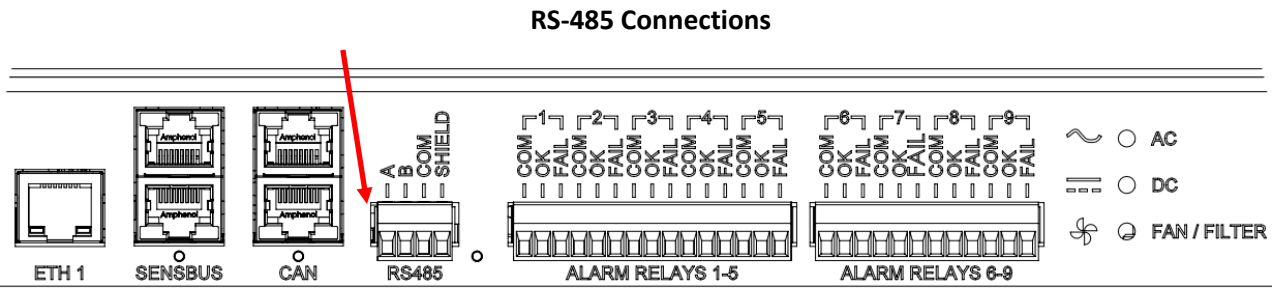

4.8.1. Termination

For proper Modbus RS-485 operation, a 120-ohm terminator is required at the ends of the RS-485 bus. If multiple devices are on the bus, only the devices on the ends of the network bus need termination resistors. The figure below shows an example of how to terminate the network. Termination may be provided as part of the network cabling or 120-ohm termination plugs for the

RJ-45 communications connector on the system are available to order separately (SENS p/n 803707). SENS units are follower devices. Pull-up and pull-down resistors are optional per Modbus specifications.

Typical Modbus Termination

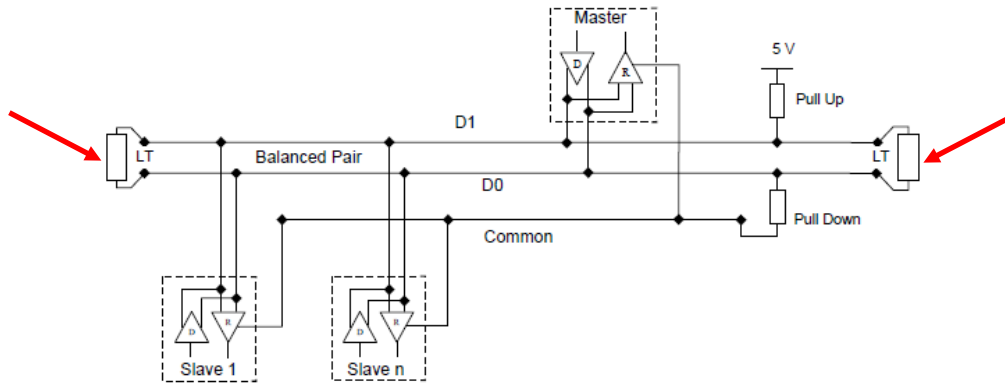

LT = Line Termination 120-ohm resistor

4.9. Ethernet

The unit is equipped with an ethernet RJ45 port (labeled “ETH1”). Connect Cat5 or better ethernet cable. This provides a 10/100 ethernet connection. P-clamps provided with system (see envelope inside cabinet) to install and route alarm wiring as desired. Ethernet communications includes ethernet connectivity to the system for monitoring and configuration via the SENS Setup Utility, Modbus TCP/IP (standard on all systems) and DNP3 (optional).

Units with Sodium Nickel Chloride (NaCl) batteries include an alternate connection for Modbus TCP/IP (labeled “MODBUS TCP/IP”). Connect Modbus communications to this port instead of ETH1 to receive Modbus information from the batteries and all devices in the system. See separately provided system diagrams for location in cabinet. The ETH1 ethernet port is still available but will not include Modbus information from the batteries. Always use the ETH1 port for connection of the SENS Setup Utility.

ETH1 Ethernet Connection

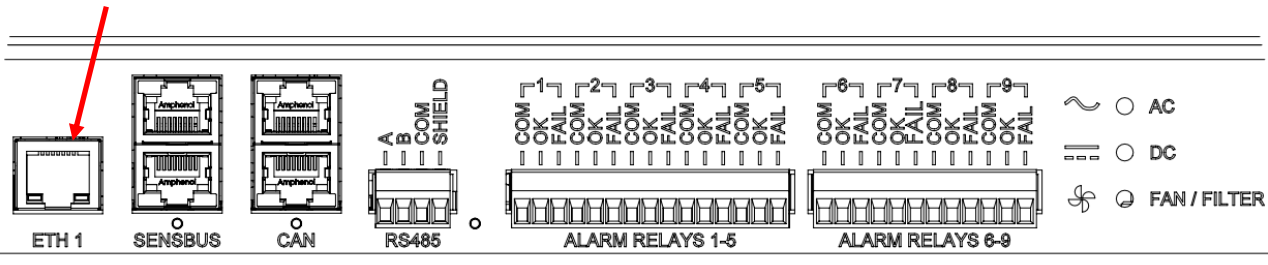

4.9.1. Configure TCP/IP Address

Configure TCP/IP settings when connected to the ETH1 ethernet port using the SENS Setup Utility or the keypad (see section 7.10.3). See section 9 for Modbus details for all devices in the system except NaCl batteries. See section 11 for NaCl Modbus details. Set the IP address as desired. It may take up to 10 seconds for the network setting changes to apply. A TCP/IP address of 0.0.0.0 implies DHCP (Dynamic) addressing. Adjust the Gateway and Subnet Mask values as required. The “Hardware Address” displayed on the front panel LCD is the MAC address corresponding to the ETH1 interface. The MAC address for the optional NaCl batteries MODBUS TCP/IP connection is stated on the label near the connection port. The MAC address values are not adjustable.

4.10. Service Connection

The unit is equipped with a Service RJ45 port. This SENSbus connection is used for internal devices and SENS accessory connections. Do not connect multiple PowerCab2 systems together using this connection unless directed to on the separately provided system diagrams.

Service Connection

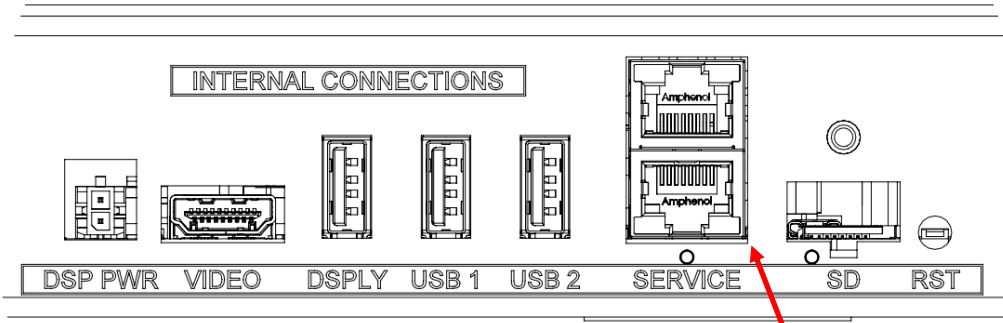

4.11. Verify Connections

- 4.11.1. Verify that all connections are secure and in the proper locations. Tighten all unused screws on terminal blocks to secure them against vibration.
- 4.11.2. Ensure all wires are routed in a way that access covers and doors or other objects will not pinch or damage them.

4.12. Verify Covers

- 4.12.1. Verify that all covers are re-installed. These covers provide the necessary air partition for cabinet cooling. The air partition extends the entire length from the top to the bottom of the cabinet.

5 START-UP PROCEDURE

5.1. Connect Battery

Close system BATTERY and CHARGER circuit breakers to connect the battery to the charger.

5.2. Verify Configuration

Each PowerCab2 system comes configured for its application from the factory. Configuration details are provided on the configuration label. The Config Code indicates charging algorithm and alarm setpoints configured at the factory. Review and adjust charger configuration using the front panel keypad or the SENS Setup Utility if factory configured settings require modification. See section [7.10](#) for additional details on keypad navigation.

Example Configuration Label (inside front door)

AC INPUT: 400-480VAC 50-60 Hz 3Ø 96.0 AMPS

DC OUTPUT: 120 VDC(NOM)
 300 AMPS - FACTORY INSTALLED
 400 AMPS - MAX CAPACITY

MAC ADDRESS: 00-80-A3-C5-58-44

OUTPUT CONFIGURATION:
 FLOAT: 133.1VDC BOOST: 138.0VDC BATT TYPE: FLA CONFIG CODE: NGN

ALARM ASSIGNMENTS (SHIPPED BY FACTORY):

SUMMARY			AC FAIL +	BATT	HIGH	LOW	ASSIGN-	ASSIGN-	ASSIGN-	ASSIGN-													
			CHGR FAIL	DISCHRG	DC	DC	ABLE	ABLE	ABLE	ABLE													
			RLY 1	RLY 2	RLY 3	RLY 4	RLY 5	RLY 6	RLY 7	RLY 8	RLY 9												
COM	OK	FAIL	COM	OK	FAIL	COM	OK	FAIL	COM	OK	FAIL	COM	OK	FAIL	COM	OK	FAIL	COM	OK	FAIL	COM	OK	FAIL
○	○	○	○	○	○	○	○	○	○	○	○	○	○	○	○	○	○	○	○	○	○	○	○

SUMMARY: COMBINATION OF RELAY ALARMS

○ COM RLY 12

○ OK

○ FAIL

○ COM RLY 11

○ OK

○ FAIL

ASSIGN-ABLE

ASSIGN-SUMMARY

○ COM RLY 14

○ OK

○ FAIL

○ COM RLY 13

○ OK

○ FAIL

ASSIGN-ABLE

ASSIGN-ABLE

SCAN FOR MANUAL

150VDC/3A OR 240VAC/10A

5.3. Apply AC Input Voltage

Verify the AC input is the correct value (188-528 VAC, 47-63 Hz) and apply AC by closing the system AC circuit breaker.

Depending on the state of charge of the batteries and the load on the DC bus, the system charger may go into current limit at this time, in which case the output voltage will be reduced as the charger operates in constant current mode. Eventually as the battery is charged, the charging current demand will taper to a value below the current limit setpoint of the charger, and the charger will revert to constant voltage output. Chargers configured to use Autoboot will operate in the boost mode for variable time ranging from a few minutes to several hours depending on state of charge of the batteries. When in the Autoboot mode, the charger will automatically revert from boost to float mode if the Autoboot system has not automatically reverted to float prior to 24 hours. This is a safety feature which, if activated, should be investigated.

5.4. Connect DC Distribution Outputs

Close each DC distribution breaker to connect external loads and devices to system DC output voltage.

5.5. Power Off

Power system off as necessary by shutting off the AC, CHARGER, and BATTERY breakers in any order.

6 ALARMS, LEDS AND DISPLAY

6.1. LED Indicators

The system is equipped with two LEDs on the main display, one for AC status and one for DC status. See further alarm definitions in section [6.5](#). See section [11](#) for optional Sodium Nickel Chloride (NaCl) battery LED indicators.

LED Definitions

AC LED	DC LED	Meaning
OFF	OFF	AC and DC not applied or charger failed or alarm/communications circuit board cannot communicate with main circuit board
SOLID GREEN	SOLID GREEN	AC good, DC good, in Float Mode
SOLID GREEN	FLASHING GREEN	AC good, in Dynamic Boost Mode
SOLID GREEN	FLASHING 2X GREEN	AC good, DC in current limit (max charge)
SOLID GREEN	FLASH LONG-SHORT GREEN	AC good, HELIX Eco-Float mode
SOLID GREEN	FLASH LONG-2X SHORT GREEN	AC good, HELIX Refresh Charge mode
SOLID GREEN	FLASH LONG-SHORT YELLOW	AC good, battery commissioning mode active
SOLID GREEN	FAST FLASHING GREEN	AC good, battery check in progress
SOLID GREEN	FAST FLASHING YELLOW	AC good, battery check failure
SOLID GREEN	SOLID RED	AC good, charger fail or overvoltage shutdown (charger disabled)
SOLID GREEN	FLASHING RED/YELLOW	AC good, reverse polarity detected on output
SOLID GREEN	SOLID YELLOW	AC good, high or low DC voltage (above/below alarm setpoint)
SOLID GREEN	FLASHING GREEN/RED	AC good, system DC output good, some individual charger module(s) in alarm state
SOLID GREEN	FLASHING RED/YELLOW	AC good, incompatible battery (charger disabled)
SOLID GREEN	FLASHING YELLOW	AC good, positive/negative ground fault present
SOLID GREEN	FLASHING GREEN/YELLOW	AC good, output limited by high temperature
SOLID GREEN	DOUBLE FLASH YELLOW	AC good, load share fail
SOLID GREEN	DOUBLE FLASH RED	AC good, load sharing DC negative connection open or load sharing charger address fault
SOLID YELLOW	SOLID GREEN	AC voltage/frequency out of range or AC phase missing, DC voltage good
SOLID RED	SOLID GREEN	AC fail or over max voltage, DC voltage good
SOLID RED	SOLID YELLOW	AC fail, high or low DC voltage (above/below alarm setpoint)
SOLID RED	SOLID RED	AC fail, charger fail or overvoltage shutdown (charger disabled)
SOLID RED	FLASHING RED/YELLOW	AC fail, incompatible battery (charger disabled)
SOLID RED	FLASHING YELLOW	AC fail, positive/negative ground fault present
	FLASH LONG-2X SHORT YELLOW	SENSbus Inactive
	ALTERNATING FLASHING YELLOW	Illegal jumper configuration
	ALTERNATING FLASHING RED	Missing or invalid code (boot load required)
	ALTERNATING FLASHING GREEN	Charger starting up

6.2. Individual Alarm Relay Contacts

The standard alarm/communications circuit board offers nine alarm discrete Form C contacts. The Form C relay contacts change state when alarms are activated. Alarm relay assignments are custom configurable to any of the alarm functions listed in section [6.5](#). See configuration label on inside front door for original factory alarm relay assignments. See section [4.5](#) for typical alarm relay assignments. The relays can be configured to be latching or non-latching with adjustable delays using the SENS Setup Utility.

By default, the relay contacts change state 30 seconds after the onset of a fault. The relay delay is configurable using the front panel keypad (see section [7.10](#)) or the SENS Setup Utility. See section [6.5](#) for alarm definitions.

6.3. LCD Panel

A two line by twenty-character LCD is included with every system and provides precision digital AC and DC ammeters and voltmeters as well as information about input, output, charging status and alarms. The voltmeters are accurate to $\pm 1\%$ and the ammeters are accurate to $\pm 1\%$. The display is readable with or without ambient lighting and operates automatically, requiring no operator intervention.

The LCD is fully operational from -20°C to $+50^{\circ}\text{C}$. It may temporarily become unreadable below -20°C but should recover as temperature increases. LCD life is reduced with sustained operation above 65°C .

6.4. Latched Alarms

All alarm messages displayed on the front panel LCD are latching. Alarm relay configurations created using the SENS Setup Utility may be configured as latching if desired. Once an alarm condition no longer exists, the alarm message will no longer display in the main/home screen but will remain under the “Latched Alarms” menu. Clear latched alarms using the keypad under the “Latched Alarms” menu (see section [7.10.3](#)), using the SENS Setup Utility or by cycling power.

6.5. Alarm Definitions

See section [6.1](#) for a description of LED indicator activity. Unless noted otherwise, the following alarms are displayed on the LCD panel.

6.5.1. AC Line Failure

Indicates AC input voltage is not detected or is outside of the allowed 188-528VAC range. Activates solid red AC LED. When this alarm is assigned to a relay contact AC LINE FAIL will cause the assigned relay to change to the Failed state after the time delay.

6.5.2. High DC Voltage

Indicates DC output voltage is above the High DC Voltage factory alarm setpoint or the configured level if setpoint is adjusted using keypad or SENS Setup Utility. Activates solid yellow DC LED. When this alarm is assigned to a relay contact HIGH DC VOLTAGE will cause the assigned relay to change to the Failed state after the time delay.

6.5.3. Battery on Discharge

Indicates battery is beginning to discharge and DC output voltage is below Battery Discharge Voltage factory alarm setpoint or the configured level if setpoint is adjusted using keypad or SENS Setup Utility. The BATTERY DISCHARGING alarm is the first to trigger of three low output voltage alarms and is followed by LOW DC and then END OF DISCHARGE. Alarm setpoint must be set higher than LOW DC and END OF DISCHARGE alarms. Activates solid yellow DC LED. When this alarm is assigned to a relay contact BATTERY DISCHARGING will cause the assigned relay to change to the Failed state after the time delay.

6.5.4. Low DC Voltage

Indicates battery has discharged and DC output voltage is below Low DC Voltage factory alarm setpoint or the configured level if setpoint is adjusted using keypad or SENS Setup Utility. Alarm setpoint must be set lower than BATTERY DISCHARGING and higher than END OF DISCHARGE alarms. Activates solid yellow DC LED. When this alarm is assigned to a relay contact LOW DC

VOLTAGE will cause the assigned relay to change to the Failed state after the time delay.

6.5.5. **Battery End of Discharge**

Indicates DC output voltage is below Battery End Discharge factory alarm setpoint or the configured level if setpoint is adjusted using keypad or SENS Setup Utility. This alarm is intended only for longer discharge rates (i.e. not engine starting applications) and indicates the normal end-of-discharge voltage for a lead-acid battery. Alarm setpoint must be set lower than LOW DC and BATTERY DISCHARGING alarms. Activates solid yellow DC LED. When this alarm is assigned to a relay contact BATTERY END OF DISCHARGE will cause the assigned relay to change to the Failed state after the time delay.

6.5.6. **Charger Module Fault**

Indicates one or more individual module(s) in a system are in an alarm state. Activates flashing green/red DC LED. When this alarm is assigned to a relay contact INDIVIDUAL MODULE FAULT will cause the assigned relay to change to the Failed state after the time delay. The alarming module is indicated by position number in the alarm message on the LCD. Charger module position numbers are assigned as shown below.

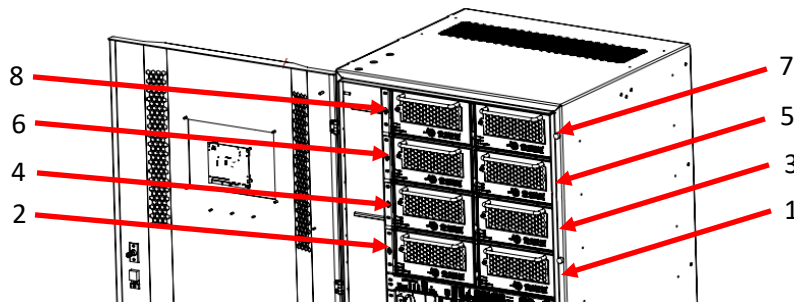

6.5.7. **Charger Failure**

Indicates a power module within the system has failed. One or more power modules is not able to provide the current demanded by the battery and/or load or is providing more current than the control system is commanding. This alarm is typically caused by a module internal component failure. This alarm does not occur during AC power failures. Activates solid red DC LED. When this alarm is assigned to a relay contact CHARGER FAIL will cause the assigned relay to change to the Failed state after the time delay.

6.5.8. **Over Voltage Shutdown**

Indicates the system charger has executed a high voltage shutdown and DC output voltage is above Over Voltage Shutdown factory alarm setpoint or the configured level if setpoint is adjusted using keypad or SENS Setup Utility. The charger disables itself whenever excessive output voltage occurs while the charger is delivering current. The overvoltage shutdown system is protected against nuisance trips and will not execute if the high voltage condition is caused by an external source including a parallel connected charger of any type. Activates solid red DC LED. When this alarm is assigned to a relay contact OVERVOLTAGE SHUTDOWN will cause the assigned relay to change to the Failed state after the time delay.

6.5.9. **Reverse Polarity**

Indicates battery is connected backwards. System charger output is disabled until the condition is corrected. Activates flashing red/yellow DC LED. When this alarm is assigned to a relay contact REVERSE POLARITY will cause the assigned relay to change to the Failed state after the time delay.

6.5.10. **Incompatible Battery**

Indicates system charger is connected to an incompatible battery. The charger operates for approximately 5 minutes while observing behavior of the DC voltage. If DC voltage behavior is normal the charger will continue charging. If DC voltage behavior is abnormal, as is typical with a

battery voltage mismatch, the charger will shut down and lock off after approximately five minutes. Activates flashing yellow DC LED. When this alarm is assigned to a relay contact INCOMPATIBLE BATTERY will cause the assigned relay to change to the Failed state after the time delay. After correcting mismatched condition cycle power to reset the charger and begin operation. See section [7.5](#) for charging a very low or zero-volt battery, when this safety feature would be a nuisance.

6.5.11. Invalid Settings

Indicates settings are not valid. Output is disabled until the condition is corrected. Activates alternating flashing yellow AC and DC LEDs. When this alarm is assigned to a relay contact INVALID SETTINGS will cause the assigned relay to change to the Failed state after the time delay.

6.5.12. Fan Fail

Indicates a problem with one of more of the fans in a power module. When this alarm is assigned to a relay contact FAN FAIL will cause the assigned relay to change to the Failed state after the time delay.

6.5.13. SENSbus Inactive

Indicates the system is not communicating on SENSbus either when load sharing and/or remote accessories are connected. Activates flashing long then 2x short yellow AC and DC LEDs. When this alarm is assigned to a relay contact SENSBUS INACTIVE will cause the assigned relay to change to the Failed state after the time delay.

6.5.14. Thermal Fold Back

Indicates output power has been reduced to protect from over-heating. The system charger will not be able to produce full output until the ambient temperature is lowered. When this alarm is assigned to a relay contact THERMAL FOLDBACK will cause the assigned relay to change to the Failed state after the time delay.

6.5.15. No Remote Temp Sense

Indicates disabled or failed remote temperature sensor. This alarm is only available when a remote battery temperature sensor is installed with the optional remote battery monitor. When the temperature probe sensor is shorted temperature compensation is turned OFF. When this alarm is assigned to a relay contact TEMPERATURE PROBE FAULT will cause the assigned relay to change to the Failed state after the time delay.

6.5.16. Current Limiting

Indicates the system charger is operating at maximum allowable output, either the maximum current setting or maximum power output (whichever occurs first). Activates flashing green DC LED. When this alarm is assigned to a relay contact CURRENT LIMITING will cause the assigned relay to change to the Failed state after the time delay.

6.5.17. Ground Fault Positive

Indicates a short circuit or high impedance leakage current exists from the system positive to ground. Systems are shipped with this alarm disabled. Ground fault settings can be adjusted using the front panel keypad. Adjustments include ground fault polarity and sensitivity. The sensitivity adjustment range is from 0 (OFF) to 5,000 μ A in 100 μ A increments. Setup Error code will alert user if this is adjusted beyond the system capability. Activates flashing yellow DC LED. When this alarm is assigned to a relay contact GROUND FAULT POSITIVE will cause the assigned relay to change to the Failed state after the time delay. Using the keypad, navigate to the "DC Meters" menu to view detected ground fault voltage and current.

6.5.18. Ground Fault Negative

Indicates a short circuit or high impedance leakage current exists from the system negative to ground. Systems are shipped with the ground fault alarm disabled. Ground fault settings can be adjusted using the front panel keypad. Adjustments include ground fault polarity and sensitivity. The sensitivity adjustment range is from 0 (OFF) to 5,000 μ A in 100 μ A increments. Setup Error code will alert user if this is adjusted beyond the system capability. Activates flashing yellow DC LED. When this alarm is assigned to a relay contact GROUND FAULT NEGATIVE will cause the assigned relay to change to the Failed state after the time delay. Using the keypad, navigate to the “DC Meters” menu to view detected ground fault voltage and current.

6.5.19. Low Current

Indicates current from the system charger is below the Low Current Alarm setpoint. Unless specified by customer order, systems are shipped with the low current alarm disabled. When this alarm is assigned to a relay contact LOW CURRENT will cause the assigned relay to change to the Failed state after the time delay.

6.5.20. Load Share Fail

Indicates that system power modules connected internally are not sharing the current load. Activates double flashing yellow DC LED. When this alarm is assigned to a relay contact LOAD SHARE FAIL will cause the assigned relay to change to the Failed state after the time delay.

6.5.21. AutoBoost Lockout Active

Indicates the Boost mode time limit has expired and system has returned to Float mode. Boost mode is disabled until the time limit is reset. The Boost time limit is reset if system charger power is cycled. The Boost time limit is set to 24 hours by default. When this alarm is assigned to a relay contact AUTOBOOST LOCKOUT ACTIVE will cause the assigned relay to change to the Failed state after the time delay.

6.5.22. DC Below Startup Voltage

Indicates battery voltage is below the factory Startup Voltage setpoint or the configured level if setpoint is adjusted using keypad or SENS Setup Utility. When this alarm is assigned to a relay contact DC BELOW STARTUP VOLTAGE will cause the assigned relay to change to the Failed state after the time delay.

6.5.23. Battery Check

Indicates battery has failed the most recent battery check. This is a latching alarm. This alarm is cleared by passing a new battery check or by manual reset. When this alarm is assigned to a relay contact BATTERY CHECK will cause the assigned relay to change to the Failed state after the time delay.

6.5.24. Check Filter

Indicates system charger has experienced a thermal roll back which might be caused by a clogged input air filter. Check module input air filter and clean if needed. When this alarm is assigned to a relay contact CHECK FILTER will cause the assigned relay to change to the Failed state after the time delay.

6.5.25. Thermal Fault

Indicates module has faulted because it over heated and thermal fold-back has reached zero watts. Module output has been disabled. Cycle AC and DC power for re-initiation. This can be environmental or a sign that a fan is not working properly. When this alarm is assigned to a relay contact THERMAL FAULT will cause the assigned relay to change to the Failed state after the time delay.

6.5.26. High Battery Temperature

Indicates battery temperature is above the High Battery Temperature setpoint. This alarm is only available when a remote battery temperature sensor is installed with the optional remote battery monitor. When this alarm is assigned to a relay contact HIGH BATTERY TEMPERATURE will cause the assigned relay to change to the Failed state after the time delay.

6.5.27. High Battery Temperature Shutdown

Indicates battery temperature is high enough that the system charger has shut off as a safety concern. This alarm is only available when a remote battery temperature sensor is installed with the optional remote battery monitor. When this alarm is assigned to a relay contact HIGH BATTERY TEMPERATURE SHUTDOWN will cause the assigned relay to change to the Failed state after the time delay.

6.5.28. Charger Low Temperature

Indicates system charger is currently below its rated temperature. Output may be derated. When this alarm is assigned to a relay contact CHARGER LOW TEMPERATURE will cause the assigned relay to change to the Failed state after the time delay.

6.5.29. Battery Low Temperature

Indicates battery temperature is below the Low Battery Temperature setpoint. This alarm is only available when a remote battery temperature sensor is installed with the optional remote battery monitor. When this alarm is assigned to a relay contact BATTERY LOW TEMPERATURE will cause the assigned relay to change to the Failed state after the time delay.

6.5.30. AC Phase Missing

Indicates an AC phase is missing or out of range. Activates solid yellow AC LED. When this alarm is assigned to a relay contact AC PHASE MISSING will cause the assigned relay to change to the Failed state after the time delay.

6.5.31. AC Voltage Over Maximum

Indicates AC Voltage has gone above max allowed by the system on any phase. This alarm has a delay of 3 seconds. Output has been disabled. Activates solid red AC LED. When this alarm is assigned to a relay contact AC VOLTAGE OVER MAXIMUM will cause the assigned relay to change to the Failed state after the time delay.

6.5.32. AC Voltage Low

Indicates AC Voltage has gone below AC Min Voltage alarm setpoint. Activates solid yellow AC LED. When this alarm is assigned to a relay contact AC VOLTAGE LOW will cause the assigned relay to change to the Failed state after the time delay.

6.5.33. AC Frequency Out of Range

Indicates AC Frequency is above the AC High Frequency or below the AC Low Frequency alarm setpoint. Activates solid yellow AC LED. When this alarm is assigned to a relay contact AC FREQUENCY OUT OF RANGE will cause the assigned relay to change to the Failed state after the time delay.

6.5.34. AC Voltage High

Indicates AC Voltage is above the AC Max Voltage alarm setpoint. Activates solid yellow AC LED. When this alarm is assigned to a relay contact AC VOLTAGE HIGH will cause the assigned relay to change to the Failed state after the time delay.

6.5.35. AC SPD

Indicates supplementary AC surge protective device has degraded from repeated electrical transients and needs to be replaced. Only active with optional supplementary surge protector options. When this alarm is assigned to a relay contact AC SPD will cause the assigned relay to change to the Failed state after the time delay.

6.5.36. DC SPD

Indicates supplementary DC surge protective device has degraded from repeated electrical transients and needs to be replaced. Only active with optional supplementary surge protector options. When this alarm is assigned to a relay contact DC SPD will cause the assigned relay to change to the Failed state after the time delay.

6.5.37. AC Breaker

Indicates that AC breaker is open or has tripped. Only active with Breaker Status option. Alarm/communications circuit board AC BREAKER relay contacts change to Fail state after delay when alarm is assigned to relay contacts.

6.5.38. DC Breaker

Indicates that CHARGER breaker is open or has tripped. Only active with Breaker Status option. Alarm/communications circuit board DC BREAKER relay contacts change to Fail state after delay when alarm is assigned to relay contacts.

7 OPERATION

7.1. Charging Algorithms

The system uses charging algorithms appropriate for different battery types. The charging algorithm for each battery type includes various combinations of Float mode, Dynamic Boost™ mode, and HELIX mode. See following sections for descriptions of each charging mode.

7.1.1. Recharging Batteries

After a battery has been discharged, the system charger will enter Dynamic Boost mode if this mode is enabled (see section [7.3](#)). The charger's output voltage setpoint during Dynamic Boost mode increases to the boost voltage value (see section [7.3](#)). If the battery is deeply discharged, DC voltage will remain below the boost voltage setpoint until the charger's output current drops below its rated maximum. Charging in the boost mode continues until the Dynamic Boost control system ends the boost mode or the boost time limit expires (boost time limit set to 24 hours by default). After operating in boost mode the charger switches to Float mode (see section [7.2](#)). If HELIX mode is enabled the charger will enter HELIX mode after operating in Float for a short time.

7.2. Float Mode

Float mode is used to maintain stationary batteries in a fully charged state. When the system charger is in Float mode the output voltage is maintained at the float voltage setting. See the inside door label for original factory configuration float value.

7.3. Dynamic Boost™ Mode

Dynamic Boost is an advanced method of boost charging that automatically computes during each recharge the optimal time for the system charger to remain at the boost voltage, before transitioning back to the float charge mode. Dynamic Boost automatically adjusts for differing battery sizes, depths of discharge, varying load, battery age and other variables. Dynamic Boost mode safely maximizes recharge performance while cutting risks of both overcharging and undercharging associated with manual or automatic boost timers or earlier generation automatic boost control systems.

Dynamic Boost is automatically used by the charger depending on battery type selected. Dynamic Boost is disabled by default for VRLA and NaCl batteries. See the inside cover label for original factory configuration boost value. Batteries are automatically charged using Dynamic Boost mode when the battery requires it. Charging in boost mode continues until the Dynamic Boost control system ends boost mode or the boost time limit expires. The boost time limit is set to 24 hours by default. Dynamic Boost can be enabled or disabled by the user at any time.

Configure the charger appropriately using the keypad or SENS Setup Utility. Use of the optional remote temperature compensation probe is highly recommended to maximize charging performance and optimize battery life.

7.4. HELIX Mode

HELIX (High Efficiency, Life-eXtending) mode is a type of intermittent charging that can increase the life of some types of batteries. HELIX mode can be enabled/disabled using the keypad, the SENS Setup Utility, or by selecting a different battery type.

HELIX mode adds two DC output voltage settings to the traditional Boost and Float voltages. These are called Eco-Float and Refresh. The Eco-Float voltage is just above battery open circuit voltage, below traditional float. Refresh voltage is approximately halfway between Float and Boost voltage.

When HELIX is operating, the system charger spends more than 90% of its operating hours in the Eco-Float mode. In this mode the charger uses less energy and substantially reduces the rate at which water is lost from the battery. If there are no power outages or other battery discharge events the charger periodically transitions from Eco-Float mode to Refresh mode to ensure that the battery remains fully charged. After operating in Refresh mode the charger reverts to Eco-Float mode.

7.5. Charging Low or Zero-volt Batteries

The system includes a safety start-up voltage feature designed to prevent long-term overcharge of a battery in the event of a mismatched battery (e.g. a 120V battery is connected to a 240V charger). The default startup voltage level is factory configured to 50% of the float voltage, meaning that the system charger must detect at least 50% of nominal voltage before starting. If battery voltage remains below the low battery error threshold for more than 5 minutes, the charger will alarm “Incompatible Battery” and shut down. If DC voltage rises properly the charger will continue to charge the battery normally using standard output settings (see section [7.6](#) if alternate output settings are required). After correcting a mismatched condition, cycle AC and DC power to reset the charger and resume charging.

This safety feature can be temporarily defeated from the keypad or the SENS Setup Utility in order to charge/commission a zero-volt or fully discharged battery. Use the keypad or SENS Setup Utility to set the desired minimum startup voltage level and initiate a forced startup. If the startup voltage level is set to zero, initiation of the startup charge will occur automatically.

7.6. Commissioning Batteries

Some batteries require an initial “commissioning” charge that typically employs different charging voltage and current limit values from the normal system operating values. Set the commissioning charging voltage and current limit values using the SENS Setup Utility or keypad. Commissioning is not available for VRLA and power supply battery types. During commissioning the Over Voltage Shutdown trip point is automatically adjusted upward to approximately 102% of the commissioning charge voltage and the temperature compensation system is deactivated. After commissioning completes, the system automatically reverts to the settings configured for normal charging, including temperature compensation and the Over Voltage Shutdown trip point.

7.7. Battery Check

Battery Check determines if the system battery can support a parallel connected DC load. Battery Check reduces system charger output voltage to a configurable backstop level to permit the battery to support the load. Once Battery Check is activated by the user it can be run either manually or scheduled to run periodically. Manually activate a Battery Check, schedule a Battery Check to run automatically and configure minimum voltage and duration using the keypad or SENS Setup Utility. Upon completion of the test, the LCD displays whether the test passed or failed for ten seconds or until the “Enter” key is pressed. An in-progress Battery Check activates a fast flashing green DC LED. Battery Check failure activates a fast flashing yellow DC LED. When this alarm is assigned to relay contacts BATTERY CHECK relay contacts change to Fail state after delay. The BATTERY CHECK alarm latches by default. Clear a latched Battery Check alarm using the keypad or SENS Setup Utility.

IMPORTANT: A load less than about 3% of the system output maximum current rating may cause inaccurate battery check results. If the system load is typically lower than 3% disable the Scheduled Battery Check feature. Battery Check will not indicate whether a battery is healthy enough to recharge switchgear relays for systems in switchgear applications without a continuous current load.

7.8. Shunt Trip AC Breaker—*Optional*

Models may be equipped with a factory ordered optional shunt trip AC breaker. This feature allows for the AC breaker to automatically trip when the AC input voltage exceeds a certain level. The setting for this feature is AC Over Max Voltage. The factory setting for this feature is 550VAC with a 3 second delay. This feature may be used to protect the charger from failure due to extreme increases in AC voltage. Note – should the shunt trip be triggered, the AC breaker must be manually switched back to the ON position.

7.9. Restore Factory Defaults

Restore factory defaults using the front panel keypad or the SENS Setup Utility. The following values will revert to original factory settings:

- Battery type
- Cell count
- Float Voltage
- Boost Voltage
- Battery Discharge Voltage
- Low DC Voltage
- Battery End of Discharge Voltage
- High DC Voltage
- Battery Check Voltage
- Over Voltage Shutdown
- Temperature Compensation Slope
- Auto Boost Time Limit
- Periodic Scheduled Boost Interval
- Periodic Scheduled Boost Duration
- Low Current Alarm
- Battery Check Interval
- Battery Check Duration
- Commissioning Time
- Commissioning Charge Voltage
- Commissioning Current

7.10. Keypad Operation

The front panel keypad provides the ability to adjust charger settings without the SENS Setup Utility.

7.10.1. Security Code Protection

Chargers may be security code protected to ensure only authorized personnel may adjust charger settings. The default security code is 000000 meaning security code is not enabled. Change the security code to a unique value using the front panel keypad. Contact SENS Customer Service if a custom password is lost or forgotten (800-742-2326 or www.sens-usa.com).

7.10.2. Menu Navigation



Use the keypad to scroll through settings to view and adjust. The keypad provides X-Y navigation with main fields up and down and details within each field left and right. Press the up and down arrow keys to scroll through main menu options. Press the left and right arrow keys to scroll through data available within each menu. Value adjustments are made with the up and down arrow keys. Values are saved to nonvolatile memory. Press center Enter key to return to main fields. Press center Enter key twice to return to Home screen.

Menu Navigation

Step 1	↑ or ↓ for main fields
Step 2	← or → for details within each main field
Step 3	↑ or ↓ to adjust values
Step 4	↵ to return to main fields
Step 5	↵ to return to Home screen

7.10.3. Menu Options

Input, output, temperature and alarm status are displayed on the front panel LCD by default. Press the UP or DOWN arrow to access additional menus as described below. Absolute maximum voltage limits apply to all output and alarm settings. A message is displayed indicating an adjustment is limited due to settings conflict.

Main Menus <i>(Press arrows to scroll through menu options)</i>		Configurable/Viewable <i>(Press left/right arrows to scroll through menus, press up/down arrows to configure values)</i>	Parameter Descriptions
Main Menu 	Sub Menu 		
Browse Status		Scroll left/right to view basic meters and alarms	
Latched Alarms		Clear All Latched Alarms	Clear status of all latched alarms.
DC	Meters	DC Output (<i>voltage</i>)	DC output voltage and current
		DC Output (<i>power</i>)	DC output watts and % of rated output being provided
		Battery Temp.	Temperature at battery if a remote temperature sensor is connected
		Ambient Temp.	Temperature inside charger
		GF voltage	Ground Fault voltage detected by charger and indication of whether on positive or negative battery terminal
		GF Current	Ground Fault current detected by charger and indication of whether on positive or negative battery terminal
	Basic Settings	Battery Select Type	Select type of battery to be charged - flooded lead-acid, AGM, nickel-cadmium VRLA, power supply.
		Battery Select Number of Cells	Adjust number of series cells in battery string
		Float Voltage	Adjust output Float voltage, must be greater than 60% of Boost setting
		Boost Voltage	Adjust output Boost voltage from, must be same or greater than Float setting, must not be greater than 166% of Float setting
		HELIX-EcoFloat	Enable or disable HELIX mode
		Current Limit	System current limit setting. Set to "No Limit Set" for full current capacity. Set a value in amps to limit available current. It is sometimes necessary to limit maximum charging current to the battery.
		Temp. comp./°C	Adjust temperature compensation slope from 0 to -0.30%/°C
	Boost Settings	Boost Voltage	Adjust output Boost voltage from, must be same or greater than Float setting, must not be greater than 166% of Float setting

		Auto Boost Delay	Adjust amount of time from 0 to 5 minutes to delay before entering Boost mode after power is cycled or battery type is changed. Delay affects all outputs for multiple output models.
		Auto-Boost	Enable or disable Dynamic Boost mode
		Auto Boost Limit	Adjust the maximum amount of time charger will be in Dynamic Boost mode from 1 to 255 hours. The Boost time limit is reset if charger power is cycled or an engine crank is detected.
		Boost Duration	Adjust amount of time charger will be in scheduled periodic Boost mode from 1 to 255 hours. The Boost timer is reset if charger power is cycled
		Scheduled Boost	Adjust amount of time between periodic scheduled Boost events from 1 to 180 days. Set to OFF to disable.
		Run Timed Boost	Start or stop a manual Boost cycle. Will operate in Boost mode until the Boost Duration expires.
		Next Scheduled Boost	View time until next scheduled Boost
	Battery Check	Battery Check	Start or stop a manual Battery Check.
		Clear Failure Battery Check	Press UP arrow to reset/clear Battery Check alarm on selected output
		Batt Check Time	Adjust amount of time to run Battery Check from 1 to 60 minutes
		Batt Check Vmin	Adjust minimum voltage allowed during Battery Check test, must be greater than End-of-Discharge voltage and less than 98% Float voltage
		Sched Batt Check	Adjust amount of time between scheduled Battery Check tests from 1 to 90 days
		Next Sched Batt Check	View time until next scheduled Battery Check test
	Alarms	Relay Delay Time DC	Adjust amount of time to delay activation of alarm relays after a DC alarm event takes place from 5 to 60 seconds. Alarm/comms circuit board alarm relay contacts and alarms on communications ports are delayed; LED alarm indication is not delayed.
		Ground Fault Alarm	Enable/disable or adjust setpoint to trigger positive or negative Ground Fault alarm.
		Low Crank	Adjust setpoint to trigger Low Crank alarm from 6V to 98% of Float, must be at least 2% less than Float setting
		Clear Failure Low Crank	Press UP arrow to reset/clear Low Cranking alarm on selected output
		End Discharge	Adjust setpoint to trigger Battery End-of-Discharge alarm, must be less than Low DC setting

		Low DC Voltage	Adjust setpoint to trigger Low DC voltage alarm, must be greater than End Discharge setting and less than Battery Discharging setting
		Batt Discharging	Adjust setpoint to trigger Battery Discharging alarm, must be between Low DC setting and 98% of Float setting or Eco-Float setting when HELIX is active
		High DC Voltage	Adjust setpoint to trigger High DC voltage alarm, must be greater than Boost by 2% of Float setting, must be less than 40% higher than Boost setting
		Overvolt Fault	Adjust setpoint to trigger Over Voltage Shutdown alarm, must be greater than High DC setting
		Low Current	Adjust setpoint to trigger Low Current alarm from 0% to 50% of nominal current
		High Batt Temp	Adjust setpoint to trigger High Battery Temperature alarm
		Hi BatTmp Shtdwn	Adjust setpoint to trigger High Battery Temperature Shutdown alarm
		Low Batt Temp	Adjust setpoint to trigger Low Battery Temperature alarm
		Battery Room Temp	Adjust setpoint to trigger High Battery Room Temperature alarm
	Startup Voltage	DC Start Volts	Adjust DC Startup Voltage. Set to zero to start into zero-volt battery automatically.
		Force Startup	Enables charger to attempt to charge a battery with a voltage below the DC Startup Voltage. Only enables startup on selected output.
	Commission	Batt Commission (<i>voltage</i>)	Adjust battery commissioning output voltage must be greater than or equal to Float voltage
		Batt Commission (<i>current</i>)	Adjust battery commissioning output current from 5% to 100% of nominal current rating
		Batt Commission (<i>duration</i>)	Adjust battery commissioning hours from 1 to 120 hours
		Batt Commission (<i>enable</i>)	Start or stop commissioning cycle. Charger will deliver commissioning voltage and current until commissioning hours expire.
	Advanced Settings	Restore Factory Default Settings DC	Press UP arrow to restore settings to factory configuration
		DC Output #A	Enable for PowerCab2 units
		DC Output #B	Optional for PowerCab2 units
		DC Output #C	Optional for PowerCab2 units
		DC Output #D	Optional for PowerCab2 units
AC	Meters	AC Input	AC input voltage and frequency
		AC Reference Meters	Press UP arrow to enable displaying AC meter values in the Browse Status menu area

	Basic Settings	Number of Phases	Set to 1 for single-phase or 3 for three-phase input voltage
		Nominal Volts AC	Set nominal input voltage for charger model. Must match hardware jumper/terminal block on inside of charger when jumper exists.
	Alarms	Relay Delay Time AC	Adjust amount of time to delay activation of alarm relays after an AC alarm event takes place from 5 to 60 seconds. Alarm/comms circuit board alarm relay contacts and alarms on communications ports are delayed; LED alarm indication is not delayed.
		Max Voltage	Adjust setpoint to trigger AC Voltage High alarm
		Min Voltage	Adjust setpoint to trigger AC Voltage Low alarm
		High Freq	Adjust setpoint to trigger AC Frequency Out of Range alarm
	Advanced Settings	Low Freq	Adjust setpoint to trigger AC Frequency Out of Range alarm
		Restore Factory Default Settings AC	Press UP arrow to restore settings to factory configuration
		AC Input #A	Enable for PowerCab2 units
			AC Input #B
User Access		UI Access Control	Select allowed user interface access. Access options include read-only/monitor viewing or full access adjustments for advanced users.
		Change Security Code	Change security code to desired 6 digits. The default security code is 000000 (disabled). Upon entering a security code, the display will automatically prompt user for the code to access protected menus. Menus are protected depending on configured level of access (see UI Access Control definitions above).
		Relock Access	Exit Service Mode and relock access
Service Tools	Output	Force DC Startup All	Enables charger to attempt to charge a battery with a voltage below the DC Startup Voltage. Enables startup on all outputs.
	Alarms	Clear Failures All	Press UP arrow to reset/clear failures on all outputs
		Clear Failure Low Crank	Press UP arrow to reset/clear Low Cranking alarm on all outputs
		Clear Failure Battery Check	Press UP arrow to reset/clear Battery Check alarm on all outputs
	Display	Display Type	Set to "Unit Display" to display single unit values or set to "System Display" to display system (for a system with multiple chargers) values on the unit LCD
		LCD Brightness	Adjust LCD brightness from 0 – 100%
Display Test		Press UP arrow to set all LCD segments black and DOWN arrow to clear all LCD segments	

	Alarm Test	Relay Test	Press UP arrow to set all alarm relays and DOWN arrow to clear all relays
		Check Vent Fan	Press UP arrow to turn vent fan on and DOWN arrow to turn vent fan off
		Simulate Alarms	Simulate/set alarms for testing purposes. Set AC Fail, High DC, Low DC, Charger Fail and Over Voltage Shutdown alarms true. Alarm state times out after 5 minutes.
	Advanced	Soft Reset All Devices	Press UP arrow to reset all devices in the unit/system
		Full Reboot Protocol Board	Press UP arrow to reboot protocol communications device
		Repository Config	Set to Stable
		Minimum System Number of Chargers	Enable or disable whether alarm is indicated or not. Alarm active when the number of charger modules active on SENSbus is less than the minimum charger count for the system. Disabled by default, meaning no alarm. See Error Code 301 for further details.
		Minimum Unit Number of Chargers	Enable or disable whether alarm is indicated or not. Alarm active when the number of charger modules active on SENSbus is less than the minimum charger count for the unit. Disabled by default, meaning no alarm. See Error Code 301 for further details.
Communica- tions	TCP/IP Settings	TCP-IP Address	Set TCP-IP Address
		TCP-IP Gateway	Set TCP-IP Gateway
		TCP-IP Subnet Mask	Set TCP-IP Subnet Mask
		Hardware Mask	Reads Hardware Address (MAC address of the unit)
	SENSnet	SENSnet Mode	Enable or disable SENSnet Mode. When disabled the charger will not communicate via IP address. Enabled by default.
	Modbus RS485	Modbus Configuration	Select RTU or set to OFF to disable Modbus communications. Only one RS-485 communications protocol is allowed at a time.
		Modbus Configuration Address	Adjust Modbus server address from 1 to 255. Set to OFF to disable Modbus communications.
		Modbus Configuration Parity Bit	Set Modbus parity to none, even or odd
		Modbus Configuration Baud Rate	Adjust Modbus baud rate, 230.4 Kbps maximum
		Modbus Configuration Write	Enable or disable write access via Modbus
	Modbus TCP	Modbus Configuration	Enable or disable Modbus TCP-IP
		Modbus Configuration Address	Adjust Modbus server address from 1 to 255. Set to OFF to disable Modbus communications.
		Modbus Configuration Write	Enable or disable write access via Modbus

		Modbus Configuration Max Connections	Set number of clients allowed to connect at once
	DNP3 RS485	DNP3 Configuration	Enable or disable DNP3 RS-485. Only one RS-485 communications protocol is allowed at a time.
		Source Addr	Set DNP3 source address
		Dest Addr	Set DNP3 destination address
		Parity Bit	Set DNP3 parity to none, even or odd
		Baud Rate	Adjust DNP3 baud rate, 230.4 Kbps maximum
		Conf File	Set to factory default DNP3 configuration or select one of two custom configurations. Use SENS DNP3 Config Tool to generate custom configuration file.
		DNP3 TCP	DNP3 Configuration
	Port		Set DNP3 port
	Source Addr		Set DNP3 source address
	Dest Addr		Set DNP3 destination address
	Conf File		Set to factory default DNP3 configuration or select one of two custom configurations. Use SENS DNP3 Config Tool to generate custom configuration file.
	User CAN	User CAN Mode	Enable or disable User CAN Mode
Alarm Relays		Relay Delay Time AC	Adjust amount of time to delay activation of alarm relays after an AC alarm event takes place from 5 to 60 seconds. Alarm/comms circuit board alarm relay contacts and alarms on communications ports are delayed; LED alarm indication is not delayed.
		Relay Delay Time DC	Adjust amount of time to delay activation of alarm relays after a DC alarm event takes place from 5 to 60 seconds. Alarm/comms circuit board alarm relay contacts and alarms on communications ports are delayed; LED alarm indication is not delayed.
		Relay Test	Press UP arrow to set all alarm relays and DOWN arrow to clear all relays
Unit Information		Serial No.	Charger serial number
		Display Revision	Software revision currently loaded on alarms/comms circuit board
		Copyright	SENS copyright year
		Charger Revision	Software revision currently loaded on charging devices. Press UP arrow to identify device by temporarily flashing LEDs.

7.11. Configuration with SENS Setup Utility

The SENS Setup Utility is used to monitor, configure, and troubleshoot SENS chargers. Download the SENS Setup Utility software at sens-usa.com/support/download-center/. The setup utility allows configuration of all charger settings including alarm relay assignments. Update charger firmware for all devices except the communications protocol circuit board using the setup utility. Update the communications protocol circuit board using the board webpage (see sections [4.9](#) and [7.12](#)). Communication between a computer and the charger using the SENS Setup Utility requires connection of a Cat5 minimum RJ45 cable between the ethernet port on the charger and the ethernet port on the computer (see section [4.9](#)). Connect using the “SENSnet” option in the SENS Setup Utility. See the SENS Setup Utility user manual for information on connecting to and communicating with the charger.

7.12. Protocol Communications Circuit Board

Connect to the optional protocol communications circuit board to update board firmware, download a support bundle, download logs or restart. Connect using the ethernet connection (see section [4.9](#)).

7.12.1. Connect to Protocol Communications Circuit Board

The charger ships from the factory set for DHCP and will automatically/dynamically obtain an IP address. View the IP or configure the charger to use a static IP address, subnet mask and gateway using the front panel display in the “Communications” menu area. Connection is typically to a building network using a router, but a direct ethernet connection to a computer is also possible.

7.12.1.1. Network Using Router/Gateway

Connect a network cable from the ethernet port on the protocol communications circuit board in the charger to the building network (typically at a router). Allow charger to obtain an IP address dynamically or set a static IP.

7.12.1.2. Direct Connect Ethernet

Connect a network cable from the ethernet port on the protocol communications circuit board in the charger directly to a computer when a building network is not available. Because the charger is not connected to a network/router it will likely take a "link local" IP address in the range 169.254.0.0 to 169.254.255.255. This works well if the computer is also configured to obtain an IP address automatically because the computer will also take an IP address in this range. If the charger does not obtain an IP address or communications are not working, review the computer port configuration. On the computer, navigate to Control Panel -> Network and Sharing Center -> Connections: Ethernet/Ethernet Adapter -> Properties -> Internet Protocol Version 4 (TCP/IPv4) -> Properties. If the computer port is configured to “Use the following IP address:” (rather than “Obtain an IP address automatically”), configure the charger to work on that network. Using the front panel, navigate to “Communications” menu area to set IP, subnet mask and gateway. Set a different static IP address on the same subnet as the computer (e.g. if computer is set to 192.168.50.34, set the charger to 192.168.50.35). Set TCP/IP Gateway to the IP address but with a 1 for the last digit (e.g. 192.168.50.1). Set the TCP/IP Subnet Mask to 255.255.255.0.

7.12.2. Verify Connection Using Webpage

Navigate to the protocol communications circuit board webpage by typing its IP address into a browser on the computer. A page similar to below will display if a connection exists.

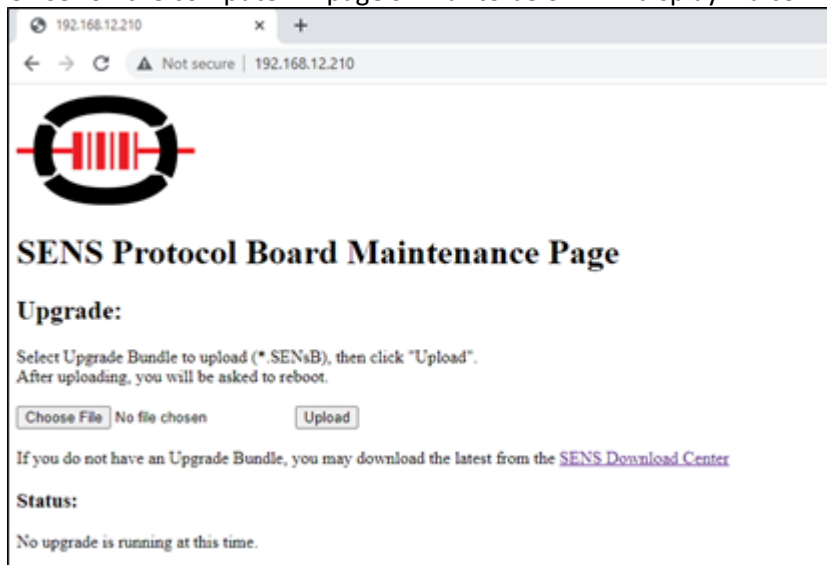

7.12.3. Update Firmware Using Webpage

Use this method to update firmware only on the protocol communications board. Update firmware for all other charger devices using the SENS Setup Utility (see section [7.11](#)).

- 7.12.3.1. Download new protocol communications board firmware bundle from the SENS website (sens-usa.com/support/download-center/). Account activation is required to enter the download center. Select the appropriate download according to the current revision of the protocol communications board. Unzip the file to extract just the firmware bundle (e.g. "SW_PROTOCOLBUNDLE_1.1.2.17405.SENsB").
- 7.12.3.2. Connect to the protocol communications board webpage (see section [7.12.2](#)).
- 7.12.3.3. Under the "Upgrade" section, select "Choose File," select the firmware bundle file to upload and press the "Upload" button.
- 7.12.3.4. Press the "Restart" button on the following page.
- 7.12.3.5. View update progress on the charger LCD and the protocol communications board webpage. The protocol communications circuit board will restart multiple times. Verify update is complete by confirming the new bundle version stated on the webpage.

7.13. Temperature Compensation

Depending on battery type, the system may be temperature compensated to match the negative temperature coefficient of the battery. When temperature compensation is active, the output voltage will increase slightly as temperature decreases, decrease as temperature increases, and is clamped at 0°C (32°F) and +40°C (122°F) to protect against extremely high or low output voltage. Temperature compensation is disabled by setting the temperature compensation slope to zero using the keypad or SENS Setup Utility.

Example Temperature Compensation Curves

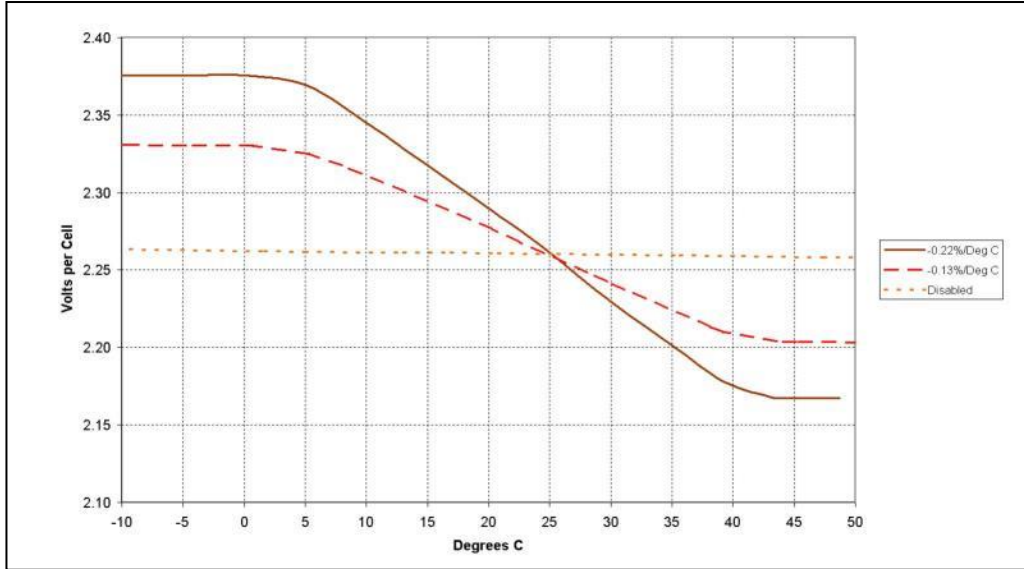

7.14. Efficiency

The figure below shows the efficiency of the system at a given input voltage for a 120VDC 50A unit with 150VDC output voltage.

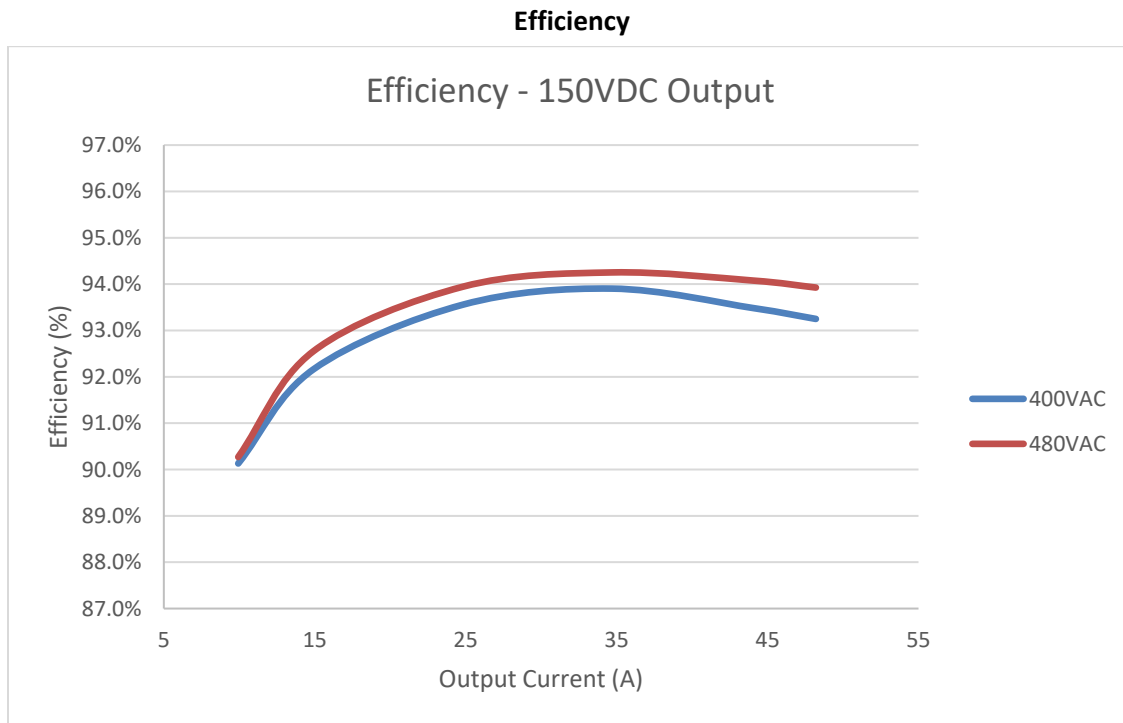

7.15. Channelization

PowerCab2 Cabinet units are equipped with a feature called channelization. Channelization allows for multiple system power modules to be assigned to different output channels, called A, B, C, or D. Multiple units can be assigned to a common load or units can be allocated to separate outputs for multiple unique loads. All of the channelized PowerCab2 units on a common communication bus can be controlled/monitored from a single point. Note that systems with the optional fan or auxiliary power supply are factory configured to use different channels.

8 SERVICE AND MAINTENANCE

8.1. Recommended Annual Maintenance

- Check all field wiring and battery connections for electrical and mechanical integrity.
- Verify no corrosion or loose hardware is present.
- Verify that convection cooling vents are not blocked or clogged on the system cabinet.
- Ensure that air filters on all power modules are clean and free from debris (see section [8.3](#)).
- Lead-acid batteries (optional) provided with the PowerCab2 must be recharged every 6 months.

8.2. Power Module Access

The PowerCab2 is powered by up to eight power modules. To remove a module, first unlock the module by moving the cam latch to the unlock position. Then pull the module out to remove. Each module weighs 23 pounds, so it may require significant force to remove the module after it is in the unlocked position. Take all necessary safety precautions given the weight of the module.

8.3. Air Filter

Each power module is equipped with an air filter accessed by removing the front grill cover. An alarm will indicate when the filter needs to be serviced. The filter can be cleaned with compressed air and re-installed.



8.4. Fans

Each power module is equipped with two fans on the top side of the unit. The fans act in parallel, so that if a fan failure occurs, the unit can continue to operate, though output power may be reduced depending on continuous loads and ambient temperature. An alarm will indicate if a fan needs to be serviced or replaced. Contact SENS for replacement components and detailed service instructions.



8.5. Supplemental Surge Protectors

If the system was ordered with the optional supplemental surge protection, these devices may need to be replaced if operated under extensive surge conditions. Should the device need to be replaced, indication will be provided on the LEDs, display, and alarms. Contact SENS for replacement components and detailed service instructions.

9 MODBUS COMMUNICATIONS

Modbus is an application layer messaging protocol used for client/server communication and is implemented according to specifications provided by Modbus Organization (<http://www.modbus.org/specs.php>).

9.1. TCP/IP Modbus

Modbus communications over TCP/IP requires configuration using the SENS Setup Utility or the keypad when connected to the standard ETH1 port. See section [11](#) to configure Modbus communications when Sodium Nickel Chloride (NaCl) batteries are included. See section [4.9](#) for connection information.

9.1.1. TCP/IP Settings Configuration – Standard ETH1 Ethernet

Adjust IP address as desired. It may take up to 10 seconds for the network setting changes to apply. A TCP/IP address of 0.0.0.0 implies DHCP (Dynamic) addressing. Adjust the Gateway and Subnet Mask values as required. The displayed Hardware Address is the MAC address corresponding to the Ethernet interface. This value is not adjustable. Configure Modbus server address and enable/disable Modbus write access as desired. See section [4.9](#) for connection information. Both Modbus TCP/IP and DNP3 TCP/IP may be used simultaneously.

TCP/IP Modbus Default Settings

Setting	Value
IP Address	0.0.0.0 DHCP/AUTO
Subnet Mask	N/A
Gateway	N/A
Port Number	502
Modbus Server Address	10

9.2. Modbus RS-485

Serial Modbus communications over RS-485 using RTU mode is optional. Modbus communications settings may be configured using the keypad or SENS Setup Utility prior to executing communications. Configure Modbus server address, baud rate, parity and enable/disable Modbus write access as desired. See section [4.8](#) for connection and termination requirements. Only one RS-485 protocol is allowed at a time. Enable/disable either Modbus RS-485 or DNP3 RS-485 using the keypad or SENS Setup Utility.

Modbus RS-485 Default Settings

Setting	Value
Configuration	RTU
Baud Rate	19200
Data Bits	8
Parity	Even
Stop Bits	1
Server Address	10

9.3. Modbus Holding Registers

PowerCab2 Modbus registers are organized using 32-bit big-endian. The registers are zero-indexed, meaning the first register is index zero as opposed to index 1. Some Modbus polling utilities may be one-indexed or default to little-endian and as such may need to be adjusted. To verify, poll register 9 as a 32-bit value and verify the first 6-digits match the serial number shown on the product label. If they don't match, adjust the offset (zero or one), change the endianness (sometimes referred to as swapping the registers) or both. Note that registers that do not have a scaling factor of one must be divided by the scaling factor to obtain the decimal/floating point representation.

The following are common registers that are applicable to most applications. Contact SENS for further information if necessary. See section [11.2](#) for Sodium Nickel Chloride (NaCl) battery Modbus registers.

Address High		Address Low		Name	Description	Units	Scale Factor
Decimal	Hex	Decimal	Hex				
0	0x000	1	0x001	Unit Serial	Serial Number of System the device was built into and shipped part of	Num	1
2	0x002	3	0x003	Program Revision	Version of the main program	Num	1
4	0x004	5	0x005	Bootloader Version	Version of bootloader	Num	1
6	0x006	7	0x007	Type	Device type	Enum	1
8	0x008	9	0x009	Serial	Serial Number of the Device	Num	1
10	0x00A	11	0x00B	Build Date	Year (16bit), month(8bit), day(8bit)	Num	1
12	0x00C	13	0x00D	Model Num 1_4	Model number character	bit	1
14	0x00E	15	0x00F	Model Num 5_8	Model number character	bit	1
16	0x010	17	0x011	Model Num 9_12	Model number character	bit	1
18	0x012	19	0x013	Model Num 13_16	Model number character	bit	1
20	0x014	21	0x015	Model Num 17_20	Model number character	bit	1
22	0x016	23	0x017	Model Num 21_24	Model number character	bit	1
24	0x018	25	0x019	Model Num 25_28	Model number character	bit	1
26	0x01A	27	0x01B	Model Num 29_32	Model number character	bit	1
42	0x02A	43	0x02B	Basic Charging Alarms	Charging Alarm status bits (see section 9.4)	Bitfield	1
44	0x02C	45	0x02D	Charging Status	Charging Status bits (see section 9.5)	Bitfield	1
46	0x02E	47	0x02F	Charging Alarms Extended	Charging Alarm Extended status bits (see section 9.6)	Bitfield	1
48	0x030	49	0x031	Charging AC Alarms	Charging AC Alarm status bits (see section 9.7)	Bitfield	1
50	0x032	51	0x033	Accessory Channel Alarms	Accessory Channel Alarm status bits (see section 9.8)	Bitfield	1
52	0x034	53	0x035	Accessory System Alarms	Accessory System Alarms status bits (see section 9.9)	Bitfield	1
54	0x036	55	0x037	Accessory Assigned Charger Alarms	Accessory Assigned Charger Alarms status bits (see section 9.10)	Bitfield	1
62	0x03E	63	0x03F	Uptime Counter Value	Charger uptime counter value	Sec	1
212	0x0D4	213	0x0D5	Unit Voltage	Voltage currently being supplied by the unit to the battery/loads	V	32768
214	0x0D6	215	0x0D7	Unit Current	Current currently being supplied by the unit to the battery/loads	A	32768

216	0x0D8	217	0x0D9	Unit Power	Power currently being supplied by the unit	W	32768
218	0x0DA	219	0x0DB	Unit Float Voltage	Float Voltage Setting of the unit	V/cell	32768
220	0x0DC	221	0x0DD	Unit Boost Voltage	Boost Voltage Setting of the unit	V/cell	32768
222	0x0DE	223	0x0DF	Unit Battery Temp	Battery temperature	°C	32768
224	0x0E0	225	0x0E1	Unit Internal temp	Internal temperature of the unit	°C	32768
226	0x0E2	227	0x0E3	Unit Boost Timer	Boost timer	Sec	1
228	0x0E4	229	0x0E5	Unit Periodic Boost Countdown	Time until next Boost	Sec	1
230	0x0E6	231	0x0E7	Unit Line Frequency	AC Line Frequency	Hz	10
232	0x0E8	233	0x0E9	Unit Line Voltage 1	AC Line 1 Voltage	V	32768
234	0x0EA	235	0x0EB	Unit Line Current 1	AC Line 1 Current	A	32768
236	0x0EC	237	0x0ED	Unit Line Voltage 2	AC Line 2 Voltage	V	32768
238	0x0EE	239	0x0EF	Unit Line Current 2	AC Line 2 Current	A	32768
240	0x0F0	241	0x0F1	Unit Line Voltage 3	AC Line 3 Voltage	V	32768
242	0x0F2	243	0x0F3	Unit Line Current 3	AC Line 3 Current	A	32768
244	0x0F4	245	0x0F5	Battery Check Time Elapsed	Battery Check time elapsed	Sec	1
246	0x0F6	247	0x0F7	Unit Battery Check Due	Time until next Battery Check	Sec	1
248	0x0F8	249	0x0F9	Unit Number of Chargers	Number of modules	Num	1

9.4. Basic Charging Alarms Bit Definition

Bit Address		Name	Description
Decimal	Hex		
0	0x00	AC Fail	AC input voltage is not detected by the module.
1	0x01	High DC	DC output voltage is above the High DC Voltage alarm setpoint.
2	0x02	Low DC	DC output voltage is below Low DC Voltage alarm setpoint.
3	0x03	Charger Fail	Module has failed. Module is not able to provide the current demanded by the battery and/or load or is providing more current than the unit's control system is commanding.
4	0x04	Over Voltage Shutdown	DC output voltage is above Over Voltage Shutdown setpoint and unit has executed a high voltage shutdown. This only occurs when the overvoltage is caused by the charger.
5	0x05	Reverse Polarity	Battery is connected backwards. Output is disabled until the condition is corrected.
6	0x06	Unused	Unused
7	0x07	Incompatible Battery	Unit is connected to an incompatible battery and is unable to bring up the output voltage after a set period of time.
8	0x08	Invalid Settings	Settings are not valid. Output is disabled until the condition is corrected.
9	0x09	Unused	Unused
10	0x0A	Thermal Fold Back	Output power has been reduced to protect from over-heating.
11	0x0B	Temperature Probe Fault	Disabled or failed remote temperature sensor. Temperature compensation is forced OFF when sensor is shorted.

12	0x0C	Current Limiting	Charger is operating at maximum allowable output, either maximum current or maximum power, whichever occurs first.
13	0x0D	Ground Fault Positive	Ground fault current to the positive output terminal is above the Ground Fault Trip sensitivity setpoint.
14	0x0E	Low Current	Output Current is under the Low Current Alarm setpoint.
15	0x0F	Load Share Fault	Modules or chargers connected for load sharing are not sharing the current load.
16	0x10	AutoBoost Lockout Active	Boost mode time limit has expired and charger has returned to Float mode. Boost mode is disabled until the time limit is reset. The Boost time limit is reset when power is cycled.
17	0x11	Unused	Unused
18	0x12	SENS Bus Inactive	Device is not communicating on SENSbus.
19	0x13	Battery On Discharge	Battery is beginning to discharge and DC output voltage is below Batt Discharge Voltage alarm setpoint.
20	0x14	Battery End Discharge	DC output voltage is below Batt End Discharge Voltage alarm setpoint.
21	0x15	Ground Fault Negative	Ground fault current to the negative output terminal is above the Ground Fault Trip sensitivity setpoint.
22	0x16	DC Negative open	Chargers connected in parallel that suffer a loss of high current negative connection may try to route power through the SENSbus cabling. This alarm shows that a charger has detected the issue and has shut itself off. Please check battery terminal connections
23	0x17	DC Below Startup Voltage	Battery voltage is below the Startup Voltage setpoint. Unit output voltage is disabled. Forced startup feature overrides.
24	0x18	Fan Fail	There is a problem with one or more of the module fans.
27	0x1B	Battery Check	Battery has failed the most recent battery check.

9.5. Charging Status Bit Definition

Bit Address		Name	Description
Decimal	Hex		
0	0x00	Output Idle	Charging status - Output Idle
1	0x01	Follower Mode	Charging status - Follower Mode
2	0x02	Helix Float Charge	Charging status - Helix Float
3	0x03	Float Charge	Charging status - Float Charge
4	0x04	Helix Refresh Charge	Charging status - Helix Refresh Charge
5	0x05	Auto Boost Charge	Charging status - Auto Boost Charge
6	0x06	Periodic Boost Charge	Charging status - Periodic Boost Charge
7	0x07	Battery Check Active	Charging status - Battery Check Active
8	0x08	Commission Charge	Charging status - Commission Charge
9	0x09	High Charger Current	Output current is more than rated current.
10	0x0A	Unused	Unused
11	0x0B	Unused	Unused
12	0x0C	Using Battery Temperature	Charger reading battery temperature and is compensating the voltage.
13	0x0D	UltraCap Mode Active	Charger is set to charge an Ultra Capacitor.
14	0x0E	Battery Check Passed	Battery Check test successfully passed

9.6. Charging Alarms Extended Bit Definition

Bit Address		Name	Description
Decimal	Hex		
0	0x00	Check Filter	Module has experienced a thermal roll back which can be caused by a clogged input air filter.
1	0x01	Thermal Fault	Module has faulted because it over-heated and thermal fold-back has reached zero watts. Module output has been disabled.
2	0x02	High Battery Temperature	Battery temperature is above the High Battery Temperature alarm setpoint.
3	0x03	High Battery Temperature Shutdown	Battery temperature is high enough that the unit has shut off for safety precautions. Only available when a remote battery temperature sensor is installed with the optional remote battery monitor.
4	0x04	High AC Ripple Detected on Output	Charger's output ripple is above High AC Ripple Detection alarm setpoint.
5	0x05	DC Output Open	Charger has detected that the output is not connected to anything.
6	0x06	Charger Low Temperature	Unit ambient temperature is below its rated ambient temperature, unit output may be derated.
7	0x07	Battery Low Temperature	Battery temperature is below Battery Low Temperature alarm setpoint. Only available when a remote battery temperature sensor is installed with the optional remote battery monitor.

9.7. Charging AC Alarms Bit Definition

Bit Address		Name	Description
Decimal	Hex		
0	0x00	Unused	Unused
1	0x01	AC Phase Missing	An AC phase is missing or out of range. Only available in a 3-phase capable device.
2	0x02	AC Voltage Over Maximum	AC Voltage has gone above max AC voltage allowed by the charger on any phase. NOTE: This alarm has a delay of 3 seconds. Output has been disabled.
3	0x03	AC Voltage Low	AC Voltage has gone below AC Min Voltage alarm setpoint.
4	0x04	AC Frequency Out Of Range	AC Frequency is outside of the AC High Frequency and AC Low Frequency alarm setpoints.
5	0x05	AC Voltage High	AC Voltage is above the AC Max Voltage alarm setpoint.

9.8. Accessory Channel Alarms Bit Definition

Bit Address		Name	Description
Decimal	Hex		
0	0x00	Invalid Settings	Setting for this channel are invalid and must be corrected before settings may be sent to the chargers on this channel.
1	0x01	Low Current Channel	Channel Current is below Low Current alarm setpoint.
2	0x02	Invalid System Config	System configuration settings are invalid.

9.9. Accessory System Alarms Bit Definition

Bit Address		Name	Description
Decimal	Hex		
0	0x00	Invalid System Config	Configuration of system is conflicted. Charger will continue to operate but may not be fully functional until the issue is resolved.
1	0x01	AC1 SPD	The AC supplementary surge protector has expired and needs replacement.
2	0x02	AC1 Breaker	The AC breaker is open or has tripped. Only available with Breaker Status option.
3	0x03	Unused	Unused
4	0x04	Batt Breaker	The BATTERY breaker is open or has tripped. Only available with Breaker Status option.
5	0x05	DC SPD	The DC supplementary surge protector has expired and needs replacement.
6	0x06	DC Breaker	The DC breaker is open or has tripped. Only available with Breaker Status option.
7	0x07	Unused	Unused
8	0x08	Unused	Unused
9	0x09	Unused	Unused
10	0x0A	Unused	Unused
11	0x0B	System Display Board	This device is configured as a system display board. It will present information for the entire system, even if devices are not in its unit.
12	0x0C	Unused	Unused
13	0x0D	SENSbus Inactive	No other devices are found on SENSbus.

14	0x0E	Unused	Unused
15	0x0F	Unused	Unused
16	0x10	Unused	Unused
17	0x11	Unused	Unused
18	0x12	No Power Board Data	No module power boards are found on SENSbus.

9.10. Accessory Assigned Channel Alarms Bit Definition

Bit Address		Name	Description
Decimal	Hex		
0	0x00	Invalid Config	The configuration of one or more power modules in the unit is invalid.
1	0x01	Individual Module Fault	A power module in the unit has faulted.

9.11. Writable Control Flags (Coils) - Single coil writes: 0xFF00 for ON, 0x0000 for OFF

Address		Description	Details
Decimal	Hex		
16	0x010	Start/stop manual boost	ON to start, OFF to stop
17	0x011	Reset periodic boost charge schedule	ON to reset schedule, OFF is no-op
18	0x012	Start/stop battery check	ON to start, OFF to stop
19	0x013	Reset periodic battery	ON to reset schedule, OFF is no-op
20	0x014	Clear battery check failure	ON to reset alarm, OFF is no-op
21	0x015	Not applicable	Not applicable
22	0x016	Force DC Startup	ON to start, OFF to stop
23	0x017	Reset Latched Alarms	ON to reset alarm, OFF is no-op

10 DNP3 COMMUNICATIONS—Optional

DNP3 is a messaging protocol used for client/server communication and is implemented according to IEEE Standard 1815-2012. The PowerCab2 is compliant with DNP3 Subset Level 2 and supports various features of Level 3 and Level 4. PowerCab2 products provide an extensive amount of DNP3 information. The information in below sections includes common data points that are applicable to most applications. The entire list of DNP3 data points is available in the SENS DNP3 Config Tool (see section [10.3](#)).

10.1. TCP/IP DNP3

DNP3 communications over TCP/IP is optional and requires configuration using the SENS Setup Utility or the keypad. Set the IP address as desired. It may take up to 10 seconds for the network setting changes to apply. A TCP/IP address of 0.0.0.0 implies DHCP (Dynamic) addressing. Adjust the Gateway and Subnet Mask values as required. The displayed Hardware Address is the MAC address corresponding to the Ethernet interface. This value is not adjustable. Configure remaining DNP3 values and enable/disable DNP3 access as desired. See section [4.9](#) for connection information. Both DNP3 TCP/IP and Modbus TCP/IP may be used simultaneously.

TCP/IP DNP3 Default Settings

Setting	Value
IP Address	0.0.0.0 DHCP/AUTO
Source Address	4
Destination Address	3
Port Number	20000

10.2. RS-485 DNP3

Serial DNP3 communications over RS-485 is optional. Communications settings may be configured using the keypad or SENS Setup Utility. Configure DNP3 values and enable/disable DNP3 access as desired. See section [4.8](#) for connection and termination requirements. Only one RS-485 protocol is allowed at a time. Enable/disable either DNP3 RS-485 or Modbus RS-485 using the keypad or SENS Setup Utility.

DNP3 RS-485 Default Settings

Setting	Value
Source Address	4
Destination Address	3
Baud Rate	9600
Parity	None

10.3. SENS DNP3 Config Tool

The SENS DNP3 Config Tool is a worksheet that allows user configuration of all DNP3 data points. PowerCab2 products ship with a default DNP3 configuration. Use the SENS DNP3 Config Tool to create a customized DNP3 configuration file. The SENS DNP3 Config Tool is available from the communications protocol circuit board webpage (see sections [4.9](#) and [7.12](#)). Follow instructions on the “Overview” tab of the SENS DNP3 Config Tool to modify configuration and load the configuration file to the communications protocol circuit board. Select to use the custom configuration on the charger using the SENS Setup Utility or keypad.

10.4. Implementation Table

Object	Variation Number	Description
1	0	Binary Input (default)
1	1 (default)	Binary Input
1	2	Binary Input With Status
2	0	Binary Input Change (default)
2	1	Binary Input Change without Time
2	2	Binary Input Change with Time
2	3 (default)	Binary Input Change With Relative Time
10	0	Binary Output (default)
10	1	Binary Output
10	2 (default)	Binary Output Status
12	1	Control Relay Output Block
30	0	Analog Input (default)
30	1	32-Bit Analog Input with Flag
30	2	16-Bit Analog Input with Flag
30	3 (default)	32-Bit Analog Input without Flag
30	4	16-Bit Analog Input without Flag
30	5	32-Bit Floating Point with Flag
30	6	64-Bit Floating Point with Flag
32	0	Analog Change Event (default)
32	1 (default)	32-Bit Analog Change Event without time
32	2	16-Bit Analog Change Event without time
32	5	32-Bit Floating Point Analog Change Event without Time
32	6	64-Bit Floating Point Analog Change Event without Time
32	7	32-Bit Floating Point Analog Change Event with Time
32	8	64-Bit Floating Point Analog Change Event with Time
34	0	Analog Input Reporting Deadband (default)
34	1	16-Bit Analog Input Reporting Deadband
34	2 (default)	32-Bit Analog Input Reporting Deadband
34	3	32-Bit Floating Point Analog Input Reporting Deadband
40	0	Analog Output Status
40	1 (default)	32-Bit Analog Output Status
40	2	16-Bit Analog Output Status
40	3	32-Bit Floating Point Analog Output Status
40	4	64-Bit Floating Point Analog Output Status
50	0	Time and Date
50	1 (default)	Time and Date
50	3	Time and Date Last Recorded Time
60	0	Class 0, 1, 2, and 3 Data
60	1	Class 0 Data
60	2	Class 1 Data
60	3	Class 2 Data
60	4	Class 3 Data
80	1	Internal Indications (IIN)

10.5. Binary Inputs

Point	Name	Description	Default Class
0	Summary High DC	High DC detected at output terminals of unit	1
1	Summary Low DC	Output voltage is below the Low DC Voltage Threshold	1
2	Summary Charger Fail	Unit has failed or cannot produce output. Reset charger to clear alarm. If alarm continues, contact customer service.	1
3	Summary AC Fail	AC not detected by the unit	1
4	Summary Ground Fault Positive	Ground fault current to the positive output terminal is above the threshold.	1
5	Summary Ground Fault Negative	Ground fault current to the negative output terminal is above the threshold.	1
6	Summary Alarm Summary	Summary of first 6 Binary Inputs	1
7	Summary Over Voltage Shutdown	High DC voltage and output current seen on unit. Reset charger to clear alarm. If alarm continues, contact customer service.	1
9	Summary Forced Load Sharing Enabled	Load sharing is enabled when multiple charger modules are present	1
10	Summary Using Battery Temperature	Charger has a battery temperature and is compensating the voltage	1
11	Summary Temperature Probe Fault	The unit does not detect a temperature probe or the probe connection is shorted (temp comp is forced off if shorted).	1
12	Summary Equalize mode	Charger is in either Auto Boost or Periodic Boost mode	1
20	Summary AC Phase Missing	An AC phase is missing or out of range in a 3-phase capable device	2
21	Summary AC Voltage Over Maximum	AC Voltage has gone above max allowed by the charger on any phase. NOTE: This alarm has a delay of 3 seconds	2
22	Summary AC Voltage Low	AC Voltage has gone below specification of the charger	2
23	Summary AC Frequency Out Of Range	AC Frequency is outside of adjustable limits	2
24	Summary AC Voltage High	AC Voltage is above the max adjustable limit	2
40	Summary Reverse Polarity	Reverse Polarity Voltage is seen at the output terminals of the unit.	2
41	Summary Low Cranking	A low crank has been detected. Reset with the crank analyzer or by resetting the charger.	2
42	Summary Incompatible Battery	Charger was unable to bring up the output voltage after a set period of time. Example: Connecting a 12V battery when the charger is set for 24V. To clear alarm reset the charger or remove and replace a jumper.	2
43	Summary Invalid Settings	The current settings in the charger (Factory, Program, or Jumper) are not compatible with this charger. Please re-check and try again.	2

44	Summary Thermal Fold Back	Charger components are over maximum temperature; so, the power output has been lowered.	2
45	Summary Current Limiting	Charger is outputting maximum current.	2
46	Summary Low Current	Output Current is under the low current alarm threshold.	2
47	Summary Load Share Fault	Unit is unable to fully load share with other units on the SENSbus. This is typically caused by units not having the same settings.	2
48	Summary AutoBoost Lockout Active	Boost mode is disabled because the charger hit the boost time limit. This will reset upon detection of a crank, or detection of loss of AC for a set period of time.	2
49	Summary Battery On Discharge	Output voltage is below the Battery Discharge Voltage Threshold	2
50	Summary Battery End Discharge	Output voltage is below the Battery End Discharge Voltage Threshold	2
51	Summary DC Negative open	Chargers connected in parallel that suffer a loss of high current negative connection may try to route power through the SENSbus cabling. This alarm shows that a charger has detected the issue and has shut itself off. Please check battery terminal connections	2
52	Summary DC Below Startup Voltage	DC is below the startup voltage; so, the charger cannot startup.	2
53	Summary Fan Fail	There is a problem with one or more of the fans	2
54	Summary Battery Check Failed	Battery has failed the most recent battery check	2
55	Summary Helix Float Charge	Charger Mode	2
56	Summary Float Charge	Charger Mode	2
57	Summary Helix Refresh Charge	Charger Mode	2
58	Summary Auto Boost Charge	Charger Mode	2
59	Summary Periodic Boost Charge	Charger Mode	2
60	Summary Battery Check Active	Charger Mode	2
61	Summary Commission Charge	Charger Mode	2
62	Summary Battery Check Passed	Battery has passed the most recent Battery Check	2
63	Summary Check Filter	Charger has experienced a thermal roll back which can be caused by a clogged filter. Please check the filter and clean it if needed	2
64	Summary Thermal Fault	Charger has faulted because it over heated. This can be environmental or a sign that a fan is not working properly	2
65	Summary High Battery Temperature	Battery is above the high battery temp threshold	2
66	Summary High Battery Temperature Shutdown	Battery Temperature is high enough that the charger has shut off as a safety concern	2
67	Summary High AC Ripple Detected on Output	Charger's output ripple is above limit	2

68	Summary DC Output Open	Charger has detected that the output is not connected to anything	2
69	Summary Charger Low Temperature	Charger is currently below its rated temperature, output may be derated	2
70	Summary Battery Low Temperature	Battery is below adjustable temperature limit (disabled if no temperature is available)	2
71	Summary Invalid Settings DC	Settings on this channel are invalid and must be corrected before settings may be sent to the chargers on this channel.	2
72	Summary Invalid System Config	Configuration of system is conflicted. Charger will continue to run, but may not be fully functional until the issue is resolved.	2
73	Summary AC1 SPD	The surge arrestor has faulted	2
74	Summary AC1 Breaker	The breaker has faulted	2
75	Summary AC2 SPD	The surge arrestor has faulted	2
76	Summary AC2 Breaker	The breaker has faulted	2
77	Summary DC SPD	The surge arrestor has faulted	2
78	Summary DC Breaker	The breaker has faulted	2
79	Summary Sensbus Inactive	There are no other devices found on SENSbus	2
80	Summary No Power Board Data	There are no power boards found on SENSbus	2
81	Summary Module Missing	Number of modules in system or unit is less than expected	2
82	Summary Individual Module Fault	Charger module has a fault	2
83	Summary Invalid Settings AC	Settings on this channel are invalid and must be corrected before settings may be sent to the chargers on this channel.	2
84	Summary DNP Config File Error	Invalid configuration file for DNP, usually a file syntax error.	2

10.6. Binary Outputs

Point	Name	Description
10	DC ChannelA Start/stop manual boost	Start/stop manual boost. PULSE_ON to start, PULSE_OFF to stop
11	DC ChannelA Reset periodic boost charge schedule	Reset periodic boost charge schedule. PULSE_ON to reset schedule.
12	DC ChannelA Start/stop battery check	Start/stop battery check. PULSE_ON to start, PULSE_OFF to stop
13	DC ChannelA Reset periodic battery check schedule	Reset periodic battery check schedule. PULSE_ON to reset schedule.
14	DC ChannelA Clear battery check failure	Clear battery check failure. PULSE_ON to reset alarm.
15	DC ChannelA Clear low cranking failure	Clear low cranking failure. PULSE_ON to reset alarm.
16	DC ChannelA Force DC Startup	Force DC Startup. PULSE_ON to force DC Startup.
17	DC ChannelA Reset Latched Alarms	Reset Latched Alarms. PULSE_ON to Reset Latched Alarms.

10.7. Analog Inputs

Point	Name	Description	Units	Default Class	Default Deadband
0	Program Revision	Revision of application code	Num	2	1
1	DNP Revision	Revision of DNP	Num	2	1
8	Setup Error Code	Error Code defined in manual (0=No Error)	Num	2	1
20	Unit Serial	Unit Serial Number of Device	Num	2	1
21	Serial	Serial Number of Protocol Board	Num	2	1
22	Build Date	Build date (byte0=Day, byte1=Month, byte2-3=Year)	Num	2	1
40	DC ChannelA Voltage	Output Voltage	mV	1	10
41	DC ChannelA Current	Output Current	mA	1	10
42	DC ChannelA Power	Output Power	W	1	10
43	DC ChannelA Battery Temperature	Temperature used for compensation if applicable	mC	1	10
44	DC ChannelA Number Of Chargers	Number of Charger Modules on this DC channel	Num	2	1
45	DC ChannelA Maximum Power	Maximum power rating	W	2	1
46	DC ChannelA Maximum Voltage	Maximum voltage rating	mV	2	10
47	DC ChannelA Maximum Current	Maximum current output	mA	2	10
48	DC ChannelA Periodic Boost Countdown	Number of seconds until next scheduled boost	Sec	2	1
49	DC ChannelA Battery Check Due	Number of seconds until next battery check	Sec	2	1
50	DC ChannelA State Timer	Number of seconds elapsed in present state	Sec	2	1
60	AC ChannelA Line Voltage 1	AC Line Voltage on Phase 1	mVac	1	10
61	AC ChannelA Line Current 1	AC Line Current on Phase 1	mAac	1	10
62	AC ChannelA Line Voltage 2	AC Line Voltage on Phase 2	mVac	1	10
63	AC ChannelA Line Current 2	AC Line Current on Phase 2	mAac	1	10
64	AC ChannelA Live Voltage 3	AC Line Voltage on Phase 3	mVac	1	10
65	AC ChannelA Line Current 3	AC Line Current on Phase 3	mAac	1	10
66	AC ChannelA Line Frequency	AC Line Frequency	mHz	1	10
67	AC ChannelA Number Of Chargers	Number of Charger Modules on this AC channel	Num	2	1

10.8. Analog Outputs

Point	Name	Units
10	DC Alarm Delay	Sec
11	AC Alarm Delay	Sec
30	DC ChannelA End Discharge VPC	mV/cell
31	DC ChannelA Low DC VPC	mV/cell
32	DC ChannelA Battery Discharge VPC	mV/cell
33	DC ChannelA Battery Check VPC	mV/cell
34	DC ChannelA High DC VPC	mV/cell
35	DC ChannelA OVSD VPC	mV/cell
36	DC ChannelA Float Charge VPC	mV/cell
37	DC ChannelA Boost Charge VPC	mV/cell
38	DC ChannelA Commissioning VPC	mV/cell
39	DC ChannelA Cell Count	Num
40	DC ChannelA Commissioning Duration	Min
41	DC ChannelA Periodic Boost Interval	Hour
42	DC ChannelA Temp Comp Slope (400 = -4mV/cell/C)	-mVdc/cell/C
43	DC ChannelA Current Limit	A/A rated
44	DC ChannelA Ground Fault Trip Point	uA
48	DC ChannelA Low Crank VPC	mV/cell
49	DC ChannelA Low Current Alarm	A/A rated
50	DC ChannelA Auto Boost Time Limit	Min
52	DC ChannelA Battery Check Interval	Min
53	DC ChannelA Battery Check Duration	Min
54	DC ChannelA Commissioning Current	A/A rated
55	DC ChannelA Channel Rated Unit Current	mA
56	DC ChannelA Channel Rated Unit Power	W
57	DC ChannelA Startup Voltage	mV/cell
58	DC ChannelA Periodic Boost Duration	Min
62	DC ChannelA AC Voltage On Output Limit	mVac
63	DC ChannelA Battery High Temperature Limit	mC
64	DC ChannelA Battery High Temperature Shutdown	mC
65	DC ChannelA Battery Low Temperature Limit	mC
66	DC ChannelA High Battery Room Temperature Limit	mC
67	DC ChannelA Battery Over Room Temperature Limit	mC
101	AC ChannelA AC Low Frequency Limit	mHz
102	AC ChannelA AC High Frequency Limit	mHz
103	AC ChannelA High Voltage Limit	mVac
104	AC ChannelA Low Voltage Limit	mVac
105	AC ChannelA Number Of Phases Expected	Num

11 SODIUM NICKEL CHLORIDE (NACl) BATTERIES—*Optional*

The PowerCab2 system may optionally include Sodium Nickel Chloride (NaCl) batteries. NaCl batteries include an internal battery management system to optimally charge the batteries. The batteries must be warm before delivering energy; the internal battery management system automatically begins the warm-up process as soon as power is applied. All NaCl batteries include Modbus TCP/IP communications. See below for further information. Scan the QR code on the front of the battery to navigate to the full user manual for detailed operation information.

11.1. Installation, Removal and Replacement

PowerCab2 units typically come with batteries installed. Follow the installation instructions below if the batteries were provided separately. Battery removal is the reverse of installation. Replace batteries with like type and voltage only. Installation tool kit available to order separately (SENS p/n 209670-01).

11.1.1. Ensure PowerCab2 battery circuit breaker is in open/off position. It is recommended that AC input and charger DC breakers (when present) are also open/off except in installations where DC power must remain on during service.

11.1.2. Remove front battery bracket from each shelf. Loosen the diagonally-spanning bracket on the top shelf as needed. The side brackets may be loosened as needed.

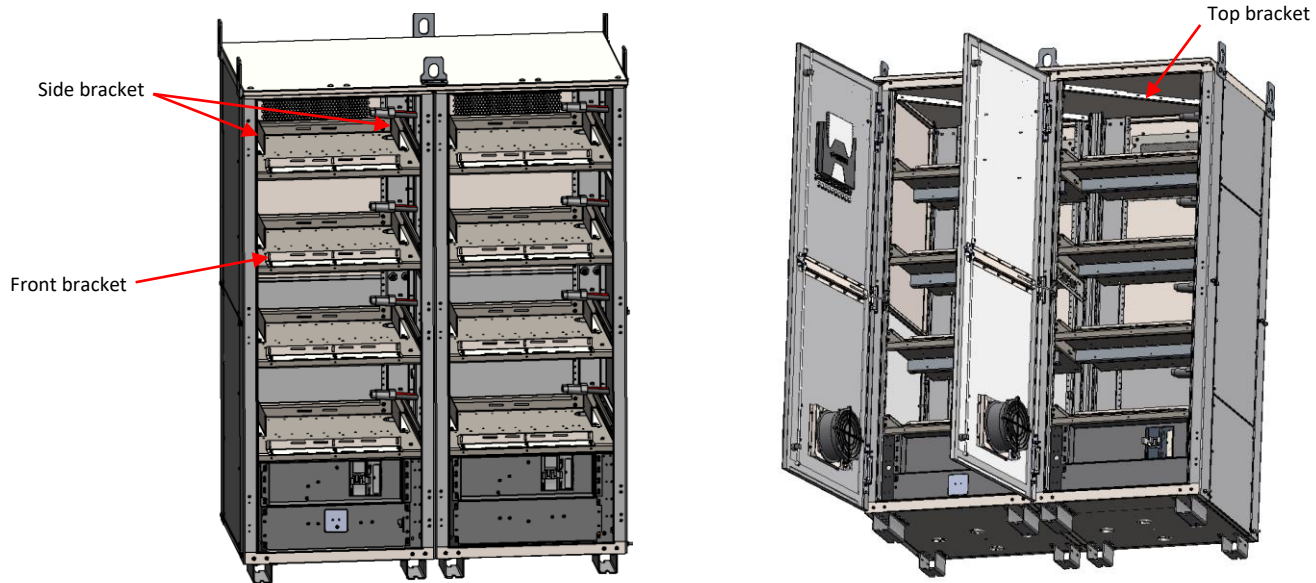

11.1.3. Slide each battery onto a shelf, fitting it between the two side brackets.











11.1.4. Replace and tighten brackets once batteries are positioned. Torque to 90 in-lbs (10 Nm).

11.1.5. Connect ground cable to each battery using an M8 nut. Torque to 97 in-lbs (11 Nm).

11.1.6. Connect DC power and Modbus communications cables to each battery. Ensure each DC power cable locking connector is firmly seated in the down position.

11.1.7. Close breakers to apply power as desired.

11.2. LED Indication

LED COLOR	INDICATION	NOTE / ACTION
 SOLID GREEN	Battery ready to operate, connected to DC bus	Battery is fully charged State of Charge (SOC) =100%
 BLINKING GREEN BLINKING BLUE	Battery warming up, not connected to DC bus	Temperature is below operational. Charging/discharging not allowed.
 SOLID GREEN SOLID BLUE	Battery under charge, connected to DC bus	Battery SOC is < 100%. Discharging is allowed
 SOLID GREEN SOLID YELLOW	Battery discharging	Battery SOC is > 12.5%
 SOLID GREEN BLINKING YELLOW	Battery discharging	Battery SOC is < 12.5%
 SOLID GREEN BLINKING RED	Warning occurred during float (idle) condition	Check float (idle) conditions/parameters
 SOLID GREEN SOLID BLUE BLINKING RED	Warning occurred while battery charging	Check charge conditions/parameters
 SOLID GREEN SOLID YELLOW BLINKING RED	Warning occurred while battery discharging	Check discharge conditions/parameters
 BLINKING GREEN SOLID RED	Alarm status – battery not connected to DC bus	Battery disconnected because of a major issue. Charging/discharging not allowed.
 NO LEDS ON	BMS is not powered-up	Check if system BATTERY breaker is open

11.3. Modbus TCP/IP

NaCl batteries Modbus TCP/IP communications are factory configured as indicated in the table below.

NaCl Batteries TCP/IP Modbus Default Settings

Setting	Value
IP Address	0.0.0.0 DHCP/AUTO
Subnet Mask	N/A
Gateway	N/A
Port Number	502
Modbus Server Address	Lowest battery in cabinet is assigned Server Address 1. Remaining batteries are assigned incrementally (2, 3, etc.) moving up in the cabinet. Charger device is assigned Server Address 10.

11.3.1. Reconfigure IP Address

If DHCP is not preferred, set a static IP address using the DeviceInstaller Software provided by Lantronix Inc. See section [4.9](#) for connection information.

Install the DeviceInstaller Software provided by Lantronix Inc. at <https://www.lantronix.com/products/deviceinstaller/>. After installing and executing the DeviceInstaller software, the search command on the toolbar menu will locate the device. The figure below displays an example of the software screen when the device is located.

Use the DeviceInstaller software to change the IP Address of the TCP/IP module by using the Assign IP command in the menu toolbar. The software will request the Device Identification (hardware address) of the module. This address is identified as “MAC” and is displayed on the charger label located near the Modbus TCP/IP port. This address is unique to each charger. Follow the software dialogue to complete the IP address setup.

Lantronix Device Located

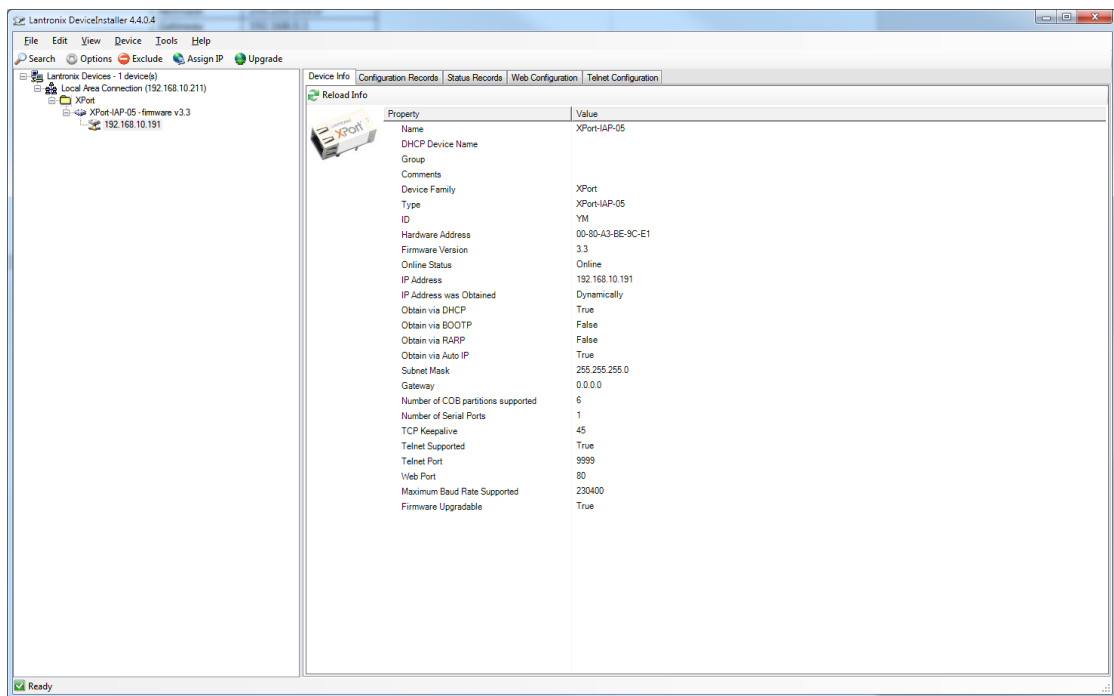

11.3.2. Reconfigure Modbus Server Address

If the default battery Modbus server address is not preferred, reconfigure using the Tera Term software provided at <https://teratermproject.github.io/index-en.html>.

- 11.3.2.1. Connect computer with Tera Term software to battery using provided USB-A to USB-A cable. The battery management system is powered via the USB, DC power is not required at the battery terminals to configure the battery.

CAUTION: If DC power is applied to the battery terminals, DO NOT power off while USB is connected. Damage will occur to the battery.

11.3.2.2. Open Tera Term and configure the “Terminal” (located under “Setup” menu) as shown:

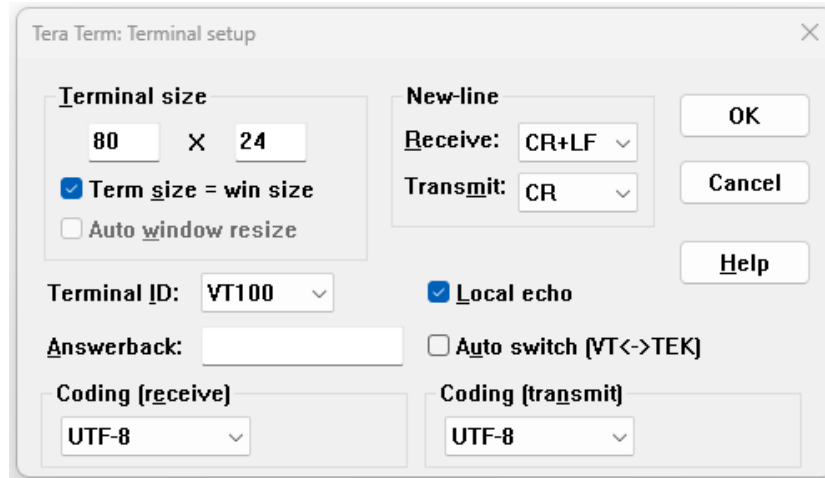

11.3.2.3. Configure the “Serial port” (located under “Setup” menu) as shown and select “New connection”:

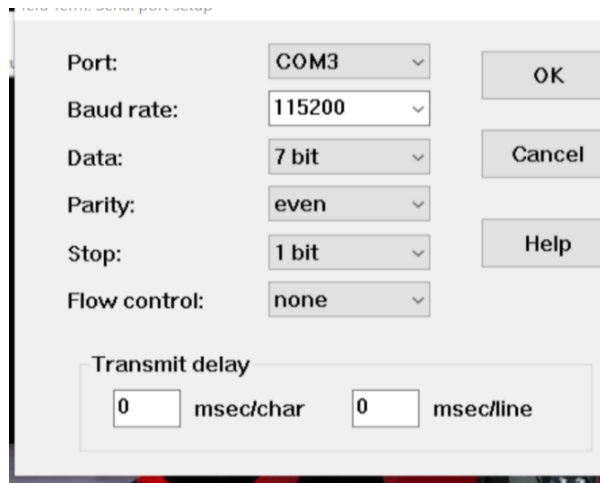

- 11.3.2.4. Read the Modbus server address already configured by typing “R209” in the console and pressing enter. Console will report server address.
- 11.3.2.5. Write a new server address by typing “W209=xx” (where xx is the new address in hexadecimal, e.g. W209=2 sets address 2) and pressing enter.
- 11.3.2.6. Save the new server address to flash memory by typing “ACT->FLASH” and pressing enter.
- 11.3.2.7. Complete the save process by typing “RESET” and pressing enter.

11.3.3. Modbus Holding Registers

The following table includes the Modbus Holding Registers for the NaCl batteries only. See section [9.3](#) for remaining system Holding Registers. Adjust polled value by the offset first, then multiply by the scale factor.

MODBUS REGISTER INDEX	REGISTER INDEX	DATA	UNIT	SCALE FACTOR	OFFSET	NOTES
999	1	BATT VOLTAGE	V	0.01	0	
1000	2	BATT CURRENT	A	0,01	-10000	
1001	3	BUS VOLTAGE	V	0.01	0	
1002	4	SOC	Ah	0.1	-10000	
1003	5	Tbatt(AVE)	°C	0.1	-400	
1004	6	LedStat	bitmap	1	0	see LED bitmap
1005	7	Warning Flags (0-15)	bitmap	1	0	see WARNINGS bitmap
1006	8	Warning Flags (16-31)	bitmap	1	0	see WARNINGS bitmap
1007	9	Warning Flags (32-47)	bitmap	1	0	see WARNINGS bitmap
1008	10	Warning Flags (48-63)	bitmap	1	0	see WARNINGS bitmap
1009	11	Alarm Flags (0-15)	bitmap	1	0	see ALARMS bitmap
1010	12	Alarm Flags (16-31)	bitmap	1	0	see ALARMS bitmap
1011	13	Alarm Flags (32-47)	bitmap	1	0	see ALARMS bitmap
1012	14	Alarm Flags (48-63)	bitmap	1	0	see ALARMS bitmap
1013	15	IO Status	bitmap	1	0	see IO bitmap
1014	16	Board_Temp	°C	0.1	-400	
1015	17	Tc_Center_Temp	°C	0.1	-400	
1016	18	Tc_Lat1_Temp	°C	0.1	-400	
1017	19	Tc_Lat2_Temp	°C	0.1	-400	
1018	20	RiscC_pwm	percent	0.1	0	
1019	21	RiscL_pwm	percent	0.1	0	
1050	52	RTC_Counter_Lo	seconds			
1051	53	RTC_Counter_Hi	seconds			
1054	56	Firmware Version				
1055	210	Batter_ID	-	-		Register contains BCD
1056	210	Batter_ID	-	-		Register contains BCD
1057	210	Batter_ID	-	-		Register contains BCD
1058	210	Batter_ID	-	-		Register contains BCD

11.3.4. Modbus Bitmap

BIT INDEX	ALARM BITMAP registers 11-14	WARNING BITMAP register 7-10	LED BITMAP register 6	IO BITMAP register 15
0	Tam		GREEN_0	MAIN_SWITCH_CLOSED
1		TaM1	GREEN_1	ALARM_OUT_ACTIVE
2	TaM2		AMBER_0	
3	Tbm		AMBER_1	VOLT_MEASUREMENT_ALLOWED
4		TbM1	BLUE_0	VOLTAGE STRING RELAY
5	TbM2		BLUE_1	REMOTE_STATE
6		VBm1	RED_0	RISC_ON
7	VBm2		RED_1	
8		VBM1		
9	VBM2			
10		IDM1		
11	IDM2			
12		ISOB		
13	MSWE			
14				
15	HTRE			
16	TCPE			
17	STRE			
18	CM E			
19	HWFL			
20	HWEM			
21	ThM			
22	vsm1			
23	vsm2			
24		vsM1		
25	vsM2			
26		iCM1		
27	iCM2			
28		iDM1		
29	iCM2			
30		MID1		
31	MID2			
32		BLPW		
33	CCBF			
34				
35		Ah_W		
36				
37	BRNF			
38				
39		TCMM		
40		TCdi		
41				
42	HTFS			
43	DATA			
44		LMPW		
45	LMPA			
46		DMMY		
47		DMMY		
48		DMMY		
49		TOCW		

50	TOCA		
51		SOCL	
52		I2TW	
53	I2TA		
54	ULAL		
55-63	NOT USED	NOT USED	

11.3.5. LED Status

LED status is encoded in two bits.

GREEN_1	GREEN_0	LED STATUS
BLUE_1	BLUE_0	
AMBER_1	AMBER_0	
RED_1	RED_0	
0	0	OFF
0	1	ON
1	0	BLINK SLOW
1	1	BLINK FAST

12 VALVE-REGULATED LEAD-ACID (VRLA) BATTERIES—*Optional*

The PowerCab2 system may optionally include VRLA batteries.

WARNING:

WORKING WITH VRLA BATERIES IS DANGEROUS. READ THE SAFETY INSTRUCTIONS IN [SECTION 1](#) OF THIS MANUAL BEFORE INSTALLING AND WIRING BATTERIES. FOLLOW INSTRUCTIONS BELOW TO SAFELY WIRE BATTERIES.

12.1. Installation, Removal and Replacement

PowerCab2 units typically come with batteries installed. Follow the installation instructions below if the batteries were provided separately. Battery removal is the reverse of installation. Replace batteries with like type and voltage only. Installation tool kit available to order separately (SENS p/n 209670-02).

- 12.1.1. Remove front battery bracket from each shelf. Loosen/remove top bracket on the top shelf as needed. Remove clear battery safety covers from each shelf.

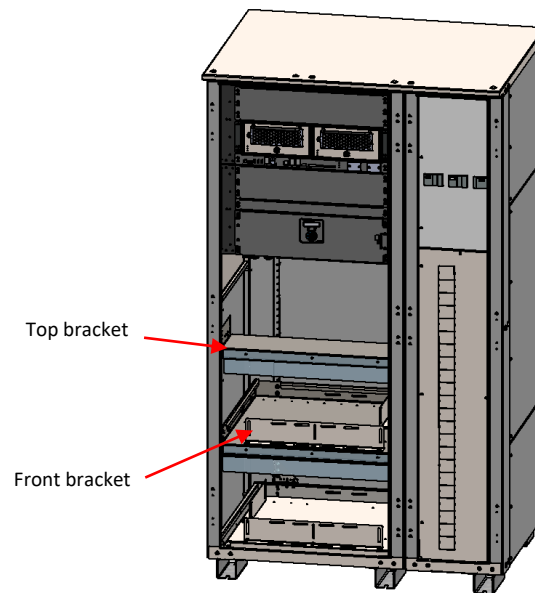

- 12.1.2. Install batteries side by side on each shelf.

WARNING:

BATTERY TERMINAL COVERS SHOULD NOT BE REMOVED UNTIL WIRING BATTERIES TOGETHER

- 12.1.3. Replace and tighten brackets once batteries are positioned. Torque to 90 in-lbs (10 Nm).
- 12.1.4. Wire batteries using instructions below.
- 12.1.5. Reinstall clear battery safety covers.
- 12.1.6. Close breakers to apply power as desired

12.2. Battery Wiring

- 12.2.1. Ensure PowerCab2 battery circuit breaker is in open/off position. It is recommended that AC input and charger DC breakers (when present) are also open/off except in installations where DC power must remain on during service.

WARNING:

EVEN WITH BREAKER OPEN, BATTERIES PRODUCE VOLTAGE AND MUST BE TREATED AS LIVE SOURCES.

LEAVE BATTERY TERMINAL PROTECTORS IN PLACE UNTIL JUST BEFORE ATTACHING A CABLE TO A TERMINAL. THIS ENSURES ONLY ONE TERMINAL IS EXPOSED AT ANY TIME.

- 12.2.2. Before connecting battery blocks together, install cross-connection cable between multiple battery shelves.
- 12.2.2.1. Attach cable to positive battery terminal first (upper shelf, right-most battery). Start hardware at “finger tight” to hold cable in position.
- 12.2.2.2. Route negative end to negative terminal on lower shelf battery (left-most battery) and install hardware.
- 12.2.2.3. Torque both terminals to 11 ft-lb (15 Nm) using insulated tools.
- 12.2.3. Install negative cable from battery circuit breaker to negative end of battery string (upper left battery terminal). Torque hardware to 11 ft-lb (15 Nm).
- 12.2.4. Install positive cable from battery circuit breaker to positive end of battery string (lower right battery terminal). Torque hardware to 11 ft-lb (15 Nm).
- 12.2.5. Secure all cables with tie-wraps and/or snap-in cable ties using holes provided in system cabinet shelves/brackets.
- 12.2.6. Install jumpers between battery blocks.
- 12.2.6.1. Start at the upper left, from battery 1 positive to battery 2 negative.

WARNING:

BE SURE TO ATTACH THE JUMPER BETWEEN TWO DIFFERENT BATTERY BLOCKS, NEVER BETWEEN TERMINALS ON THE SAME UNIT

- 12.2.11.1. Bend jumper so terminals align with battery terminals.
- 12.2.11.2. Install hardware finger-tight on each terminal, then torque both terminals to 11 ft-lb (15 Nm).
- 12.2.11.3. Repeat for remaining jumpers.

13 TROUBLESHOOTING/ERROR CODES

13.1. Reset Button

Press the RST button to reset the charger control and display circuitry. The system will take approximately 30 seconds to reset. Output voltage is not affected during reset.

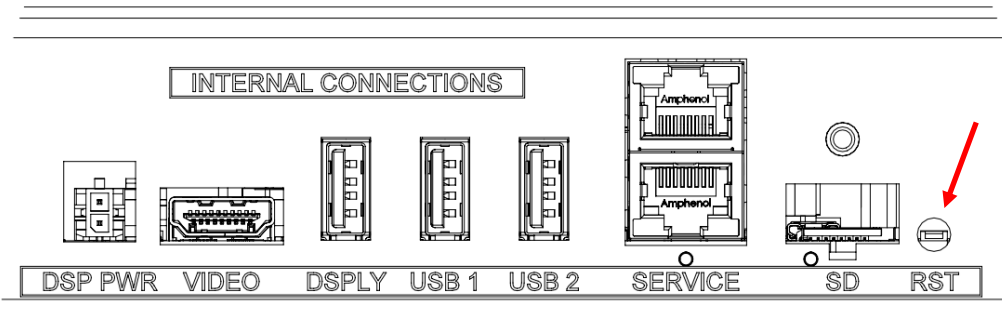

13.2. Configuration Error Codes

Error codes are displayed on front panel LCD.

Error	Scope	Description	Corrective Action
104	Charger Module	Invalid output channel. Chargers must be set to use a valid output channel setting: output channel A-D.	<ul style="list-style-type: none"> - If necessary, enable the channel using the keypad " DC Output #" selection in the "DC -> Advanced Settings " menu or the setup utility. - To select a different output channel, reassign the charger to match its actual output channel connection the setup utility.
201	Channel	No chargers assigned to output channel. Every enabled output channel must have at least one charger assigned to it. When none is found, it is presumed that a charger has failed, has lost SENSbus data communication, or has an incorrect channel setting.	<ul style="list-style-type: none"> - Check for a charger that has failed (indicated by its LED status). - Check for disconnected or damaged SENSbus data cables. - If the output channel is not to be used, disable it by using the keypad " DC Output #" setting in the " DC -> Advanced Settings " menu or the setup utility.
202	Channel	Too few chargers operating. The combined output rating of all chargers operating on this channel is less than the channel's rated output. This can occur because a charger has failed, has an open AC input or DC output connection, has lost SENSbus data communication, is configured for the wrong output channel, etc. Note: the channel output settings are used to determine channel-level output current limit settings for "N+1" and "N+2" redundant configurations; non-redundant systems use channel settings of 0 which allow up to 100% output from every available charger.	<ul style="list-style-type: none"> - Use the setup utility to verify all chargers' output channel settings. Each charger must be set for the output channel corresponding to its electrical DC output connection. Enable/disable output channels using the keypad "DC Output #" selection in the "DC -> Advanced Settings" menu or the setup utility. - Use the setup utility to verify the channel DC output current and power ratings. For "N+1" or "N+2" redundant operation use the required output rating, i.e. the total for the minimum number of chargers ("N") that will provide the necessary output ratings. Non-redundant systems use 0 settings (which disables this error check). - If necessary, install additional chargers to

			<p>meet the required output rating (plus the additional chargers needed for "N+1" or "N+2" redundant operation).</p> <ul style="list-style-type: none"> - Verify that each channel is assigned enough chargers to meet the required DC output rating (plus any extra chargers needed to provide "N+1" or "N+2" redundant operation). - Check for disconnected or damaged SENSbus data cables. - Check for miswired, disconnected, or damaged input and output connections.
203	Channel	Charger assigned to a disabled channel. All chargers must be set to a valid output channel that is enabled in this unit or system.	<ul style="list-style-type: none"> - Enable/disable output channels using the keypad "DC Output #" selection in the "DC -> Advanced Settings" menu or the setup utility. Verify that the DC outputs of all chargers assigned to this channel are electrically connected to that output bus. - To select a different output channel, reassign the charger to match its actual output channel connection using the setup utility.
305	Unit (or System)	Rogue Module Found. This can apply to any type of system. It indicates that a charger module was found that has a Unit Serial Number that does not match any display found on the bus. This could happen when adding a module from another system.	Corrective action is to fix Unit Serial Numbers on all chargers/modules and Accessory boards.

13.3. Troubleshooting Guide

AC LED	DC LED	Fan / Filter LED	Symptom	Possible Causes	Recommended Actions
OFF	OFF	-	Display AC and DC LEDs and display are off, and <u>main control board/panel LEDs are on.</u>	<ol style="list-style-type: none"> 1. Main control board to display board cable is incorrectly installed. 2. Main control board to board cable failure or poor connection. 3. Display board failure 	<ol style="list-style-type: none"> 1. Using a voltmeter, check that AC input voltage and frequency at AC input terminal block/breaker are in the range 188VAC – 528VAC / 47Hz – 63Hz or that >60VDC is present at DC output terminal block/breaker and that the DC polarity is correct. Correct charger AC input and DC output voltage as required. 2. If step 1 doesn't resolve issue, remove both AC and DC power for 1 minute, then reapply power. 3. If steps 1 and 2 don't resolve issue, determine if main control AC and DC LEDs are on (any color). If main control board LEDs

					<p>are on, check that the main control board to display board cable is correctly installed between SERVICE Port on main control board and display accessory display board J1, and that both ends of the cable are fully inserted.</p> <p>4. If step 3 doesn't resolve issue, unplug the main control board to display board cable and, using an ohmmeter, check for continuity across the cable on each pin of the cable (cable is a straight pass through). If an open connection is found, replace cable (208118-30).</p> <p>5. If cable ohms out ok, a failed display board is the likely cause. Replace display board.</p>
OFF	OFF	-	<p>Display AC and DC LEDs and display are off, and <u>main control board/panel LEDs are off.</u></p>	<ol style="list-style-type: none"> 1. Proper AC or DC voltages not applied 2. Main control board failure 	<ol style="list-style-type: none"> 1. Using a voltmeter, check that AC input voltage and frequency at AC input terminal block/breaker are in the range 188VAC – 528VAC / 47Hz – 63Hz or that >60VDC is present at DC output terminal block/breaker and that the DC polarity is correct. Correct charger AC input and DC output voltage as required. 2. If step 1 doesn't resolve issue, remove both AC and DC power for 1 minute, then reapply power. 3. If steps 1 and 2 don't resolve issue, main control board may need to be replaced. Contact SENS.
SOLID GREEN	FLASH or SOLID GREEN	-	<p>Unable to Communicate using MODBUS</p>	<ol style="list-style-type: none"> 1. No communication bus termination installed 2. Communication cable is plugged into the wrong charger port 3. Wiring is incorrect 4. Incorrect MODBUS settings (baud rate, address) 	<ol style="list-style-type: none"> 1. Verify that a terminator is installed as directed in the manual (note that a terminator is not required if the charger is not at the end of the communication bus). 2. If terminator is installed, verify that communication cable is connected to ports as directed in the manual, in the Modbus connections section. Correct cabling as required. 3. For serial applications, if cable is connected correctly, verify that Modbus +D1 (A) goes to pin 5 of

					J2 and that Modbus –D0 (B) goes to pin 4 of J2. 4. If cable wiring is correct, verify that charger and application MODBUS settings are as required. Adjust settings using setup utility as required.
SOLID GREEN	SOLID RED	-	AC good, charger fail or overvoltage shutdown	1. Charger has experienced an unexpected fault 2. Programmed settings are incorrect (OVSD set too low) 3. Charger module failure	1. Remove both AC and DC power for 1 minute, then reapply power. 2. If fault remains, check overvoltage shutdown settings and again remove both AC and DC power for 1 minute, then reapply power. 3. If steps 1 and 2 don't resolve issue, a charger module failure is the likely cause. Investigate individual modules for LED errors.
SOLID GREEN	FLASHING RED/ YELLOW	-	Charger's output is not enabled	1. A battery is connected to the charger output with reverse polarity	1. Correct DC polarity applied to DC output terminal block/breaker.
SOLID GREEN	SOLID YELLOW	-	AC good, high battery voltage	1. Alarm setpoint incorrect for application 2. DC voltage is high due to an external source	1. Check that charger battery settings and alarms are set appropriately for the application and battery under charge. 2. If settings and alarms are correct, check and correct battery / load voltage (consider battery surface charge and any other connected equipment).
SOLID GREEN	SOLID YELLOW	-	AC good, low battery voltage	1. Alarm setpoint incorrect for application 2. Battery discharged or defective	1. Check that charger battery settings and alarms are set appropriately for the application and battery under charge. 2. If settings and alarms are correct, check and correct battery / load voltage (consider loads and any connected equipment).
SOLID GREEN	FLASHING GREEN/ RED	-	AC good, system DC output good, some individual charger module(s) in alarm state	1. One or more system charger modules has an alarm.	1. Troubleshoot issue using fault code from individual charger module(s).
SOLID GREEN	FLASHING YELLOW		AC good, low incompatible battery error	1. Voltage range improperly set	1. Check that charger voltage range is set correctly for the battery. After making any correction to the range setting,

			(charger disabled)		remove both AC and DC power for 1 minute, then reapply power.
SOLID GREEN	FLASHING GREEN/YELLOW	-	AC good, output power limited	1. Charger power is reduced to protect charger due to high temperatures	1. Check for obstructions on ventilation openings 2. Ensure that all covers are installed as directed in manual. All empty module slots must have a blank cover installed. All empty equipment slots must have blank covers installed. 3. Reduce operating environment temperature. Charger will automatically increase power as temperature is lowered.
SOLID GREEN	DOUBLE FLASH YELLOW	-	AC good, load share fail	1. Charger output settings do not match between chargers	1. Check that individual charger settings are identical. Adjust as required. After making any adjustments, unplug and re-plug load share cable from charger.
SOLID GREEN	DOUBLE FLASH RED	-	AC good, output disabled	1. Too many devices on the SENSbus network	1. Ensure that less than max allowed number of devices is on the SENSbus. 2. If step 1 doesn't resolve issue, a failed main control board is likely, contact SENS
SOLID RED	SOLID GREEN	-	AC fail, battery voltage good	1. Proper AC voltages or frequency not applied 2. Charger module failure	1. Using a voltmeter, check that AC input voltage and frequency at AC input terminal block/breaker are in the range 188VAC – 428VAC / 47Hz – 63Hz. Correct charger AC input voltage as required 2. If step 1 doesn't resolve issue, a charger module failure is the likely cause. Replace module.
SOLID RED	SOLID YELLOW	-	AC fail, high battery voltage	1. Proper AC voltages or frequency not applied 2. Charger module failure And 3. Alarm setpoint incorrect for application 4. DC voltage is high due to an external source such as an alternator	AC LED 1. Using a voltmeter, check that AC input voltage and frequency at AC input terminal block/breaker are in the range 188VAC – 428VAC / 47Hz – 63Hz or that > 60VDC is present at DC output terminal block/breaker and that the DC polarity is correct. Correct charger AC input and DC output voltage as required. 2. If step 1 doesn't resolve RED AC light, remove both AC and DC power for 1 minute, then reapply power.

					<p>3. If steps 1 and 2 don't resolve RED AC light, a charger module failure is the likely cause. Replace module.</p> <p>DC LED</p> <p>1. Check that charger battery settings and alarms are set appropriately for the application and battery under charge.</p> <p>2. If settings and alarms are correct, check and correct battery / load voltage (consider battery surface charge, alternator, and any connected equipment).</p>
SOLID RED	SOLID YELLOW	-	AC fail, low battery voltage	<p>1. Proper AC voltages or frequency not applied</p> <p>2. Charger module failure</p> <p>And</p> <p>3. Alarm setpoint incorrect for application</p> <p>4. Battery discharged or defective</p>	<p>AC LED</p> <p>1. Using a voltmeter, check that AC input voltage and frequency at AC input terminal block/breaker are in the range 188VAC – 428VAC / 47Hz – 63Hz or that > 60VDC is present at DC output terminal block/breaker and that the DC polarity is correct. Correct charger AC input and DC output voltage as required.</p> <p>2. If step 1 doesn't resolve RED AC light, remove both AC and DC power for 1 minute, then reapply power.</p> <p>3. If steps 1 and 2 don't resolve RED AC light, a charger module failure is the likely cause. Replace module.</p> <p>DC LED</p> <p>1. Check that charger battery settings and alarms are set appropriately for the application and battery under charge.</p> <p>2. If settings and alarms are correct, check and correct battery / load voltage (consider loads and any connected equipment).</p> <p>3. If fault remains after the above steps, check battery health. Replace battery if weak.</p>

SOLID RED	SOLID RED	-	AC fail, charger fail or overvoltage shutdown	<ol style="list-style-type: none"> 1. Charger is in a fault state 2. Charger module failure 	<p>AC LED</p> <ol style="list-style-type: none"> 1. Using a voltmeter, check that AC input voltage and frequency at AC input terminal block/breaker are in the range 188VAC – 428VAC / 47Hz – 63Hz or that > 60VDC is present at DC output terminal block/breaker and that the DC polarity is correct. Correct charger AC input and DC output voltage as required. 2. If step 1 doesn't resolve RED AC light, remove both AC and DC power for 1 minute, then reapply power. 3. If steps 1 and 2 don't resolve RED AC light, a charger module failure is the likely cause. Replace module. <p>DC LED</p> <ol style="list-style-type: none"> 1. Remove AC and DC power from charger for 1 minute before reapplying power. Ensure AC voltage and/or DC voltage is within specified operating limits of the charge. 2. If fault remains, check overvoltage shutdown settings and again remove both AC and DC power for 1 minute, then reapply power. 3. If steps 1 and 2 don't resolve issue, a charger module failure is the likely cause. Replace module.
SOLID RED	FLASHING YELLOW	-	AC fail, low incompatible battery error	<ol style="list-style-type: none"> 1. Proper AC voltages or frequency not applied 2. Charger module failure <p>And</p> <ol style="list-style-type: none"> 3. Voltage improperly set 	<p>AC LED</p> <ol style="list-style-type: none"> 1. Using a voltmeter, check that AC input voltage and frequency at AC input terminal block (J100) are in the range 188VAC – 428VAC / 47Hz – 63Hz or that >60VDC is present at DC output terminal block/breaker and that the DC polarity is correct. Correct charger AC input and DC output voltage as required. 2. If step 1 doesn't resolve RED AC light, remove both AC and DC power for 1 minute and then reapply power. 3. If steps 1 and 2 don't resolve RED AC light, a charger module

					failure is the likely cause. Replace module. DC LED 1. Check that charger voltage is set correctly for the battery. After making any correction to the setting, remove both AC and DC power for 1 minute, then reapply power.
ALTERNATING FLASHING YELLOW	-		No output	1. Illegal configuration	1. Ensure that charger has been programmed to desired and allowable settings.
SYNCHRONIZED FLASHING YELLOW	-		No output	1. Missing terminator 2. Missing/damaged charger module	1. Verify a terminator is connected in the display board SENSbus port. 2. Ensure all charger modules are securely seated and pressed all the way into cabinet shelves. 3. If steps 1 and 2 don't resolve issue, a charger module failure is the likely cause. Contact SENS or replace charger module.
ALTERNATING FLASHING RED	-		No output	1. Missing or invalid code (boot load required)	1. Update charger firmware using setup utility. 2. If step 1 doesn't resolve issue or setup utility is not available, replace charger
ALTERNATING FLASHING GREEN	-		Starting-up	1. Charger is still powering-on 2. Failed display board	1. Remove both AC and DC power for 1 minute and then reapply power. Allow charger at least 1 minute to fully boot. 2. If step 1 doesn't resolve issue, a display board failure is the likely cause. Replace display board.
-	-	YELLOW	Filter Error	Filter Issue	1. Identify module giving error. 2. Clean module filter as directed in manual. 3. Ensure ventilation openings are not obstructed and blank covers are installed in place.
-	-	RED	Fan Error	Fan Failure	1. Identify module giving error. 2. Replace module fans as directed in manual.

14 GLOSSARY

Original Factory Configuration	Configuration set at the factory. Charger operates using settings configured at the factory per customer order. See configuration details on breaker panel label.
Float Voltage	Float output voltage is used to maintain batteries in a fully charged state and prevents a fully charged battery from becoming overcharged.
Boost Voltage	“Boost” describes an elevated output voltage employed to accelerate the recharge of a battery that is periodically discharged. The voltage employed to boost charge batteries is typically the same as that employed to “equalize” cells of a battery on long-term float charge. The terms “Boost” and “Equalize” are often used interchangeably. SENS’ convention is to employ the term “Boost” when referring to both the fast recharge function and the cell equalization function described under the definition of “Equalize Voltage”.
Equalize Voltage	“Equalize” describes an elevated voltage typically employed to reset the series-connected cells of a battery such that cell voltages and capacities more nearly match each other. Equalize charging is employed to improve the performance and life of an already charged battery that is primarily charged using Float voltage. SENS’ convention is to employ the term “Boost” to mean both this cell equalization function and the fast battery recharge function.
Battery Type	Indicates the type of battery being charged. Battery type is selected when ordering charger and may be adjusted using the front panel keypad. Supported battery types include flooded lead-acid, absorbed glass mat (AGM), valve-regulated lead-acid, and nickel-cadmium.
Configuration Code	Indicates charger output voltage configuration. Configuration code is included on the breaker panel label.
Modbus	Modbus is an application layer messaging protocol provided by Modbus Organization and used for client/server communication. Modbus is provided over RS-485 in RTU mode or over TCP/IP as an option.

SENS Limited Warranty: DC Systems

What is covered?

This warranty covers any defect in material and workmanship on PowerCab, PowerCab2, MicroCab, and PowerRack DC Systems provided by Stored Energy Systems, a Colorado Limited Liability Company (SENS).

What this warranty does not cover:

This warranty does not cover damages, defects or failures of equipment resulting from shipping damage, accidents, installation errors, unauthorized adjustment or repair, unauthorized third-party service, failure to follow instructions, misuse, fire, flood, acts of persons not in our control, and acts of God.

For how long:

Entire System: for all standard factory configurations, five years from date of shipment for PowerCab2; two years from date of shipment for other DC systems. For non-standard, custom, or special system components, the original manufacturer's warranty will apply.

Embedded battery chargers/rectifiers: five years for IQ models and PowerCab2 models, three years for MicroGenius models.

What we will do:

If your DC system is defective within the warranty period, we will, at our option, repair or replace the failed system component at no charge to you.

If we choose to replace a system component, we may replace it with a new or refurbished one of the same or similar design. The repair or replacement will be warranted for the remainder of the original warranty period. If we determine that the system cannot be repaired or replaced, we will refund its purchase price to you.

What we ask you to do:

Contact SENS service department to obtain warranty service instructions. To obtain warranty service the system component or if necessary, the system must be returned, freight prepaid, to the service facility specified by SENS under a Return Material Authorization (RMA) number provided by SENS. If, in SENS' opinion, the problem can be rectified in the field, SENS may elect to ship replacement parts for customer installation instead or in advance of returning the system component to the service facility.

Limitation:

This warranty is limited to defects in material or workmanship of the system and its components. It does not cover loss of time, inconvenience, property damage or any consequential damages. Repair, replacement or refund of the purchase price of the equipment is your exclusive remedy. No warranty is made or implied for the merchantability or fitness of the system or its components for any particular purpose.